Clixon

Release 7.8

Olof Hagsand

May 29, 2026

TABLE OF CONTENTS

1	1 Overview	3
1.1	1.1 System Architecture	3
1.2	1.2 Platforms	5
1.3	1.3 Standards	5
1.4	1.4 How to get Clixon	5
1.5	1.5 Support	6
1.6	1.6 Bug reports	6
1.7	1.7 Reference docs	6
2	2 Installation	7
2.1	2.1 Ubuntu Linux	7
2.2	2.2 FreeBSD	9
2.3	2.3 Systemd	10
2.4	2.4 Docker	11
2.5	2.5 Vagrant	11
2.6	2.6 OpenWRT	11
2.7	2.7 Prereqs from source	11
2.8	2.8 SSH subsystem	12
2.9	2.9 Configure options	12
2.10	2.10 macOS	13
3	3 Quick start	15
3.1	3.1 Host native	15
3.2	3.2 Using the CLI	16
3.3	3.3 Netconf	17
3.4	3.4 Restconf	17
3.5	3.5 Docker container	18
3.6	3.6 Next steps	18
4	4 Standards	19
4.1	4.1 YANG	19
4.2	4.2 NETCONF	20
4.3	4.3 RESTCONF	22
4.4	4.4 SNMP	23
4.5	4.5 XML and XPath	23
4.6	4.6 Pagination	25
4.7	4.7 Unicode	25
4.8	4.8 JSON	25
4.9	4.9 gRPC/gNMI	25

5	5	Configuration	27
5.1	5.1	Example	27
5.2	5.2	Loading the configuration	28
5.3	5.3	Runtime modification	28
5.4	5.4	Features	28
5.5	5.5	Finding YANG files	29
5.6	5.6	Standard YANG files	30
5.7	5.7	Extending the configuration	30
6	6	Plugins	31
6.1	6.1	Clixon_plugin_init	31
6.2	6.2	Registered callbacks	33
6.3	6.3	Reporting RPC errors	35
6.4	6.4	Plugin callback guidelines	35
7	7	Backend	37
7.1	7.1	Command-line options	38
7.2	7.2	Startup	39
7.3	7.3	IPC Socket	40
7.4	7.4	Backend files	40
7.5	7.5	Backend plugins	40
7.6	7.6	Writing a state callback	41
7.7	7.7	Transactions	43
7.8	7.8	Privileges	48
8	8	Datastore	51
8.1	8.1	Datastore files	51
8.2	8.2	File formats	53
8.3	8.3	Caching	55
8.4	8.4	Candidate	56
8.5	8.5	Module library support	58
8.6	8.6	System-only config	59
9	9	CLI	63
9.1	9.1	Overview	63
9.2	9.2	Configure options	66
9.3	9.3	Autocli	69
9.4	9.4	CLI callbacks	78
9.5	9.5	Show commands	80
9.6	9.6	Load and save commands	84
9.7	9.7	Output pipes	85
9.8	9.8	CLI aliases	88
9.9	9.9	Advanced	89
10	10	NETCONF	97
10.1	10.1	Overview	97
10.2	10.2	Starting	99
10.3	10.3	NACM	99
10.4	10.4	Confirm-commit	101
10.5	10.5	Callhome	101
10.6	10.6	Internal NETCONF	103
11	11	RESTCONF	105
11.1	11.1	Architecture	105
11.2	11.2	Installation	106

11.3	11.3	Command-line options	106
11.4	11.4	Configuration options	107
11.5	11.5	Advanced config	107
11.6	11.6	Starting	111
11.7	11.7	Plugin callbacks	113
11.8	11.8	FCGI	114
11.9	11.9	Callhome	115
11.10	11.10	HTTP data	118
11.11	11.11	RESTCONF stream notifications	119
12	12	SNMP	121
12.1	12.1	Architecture	121
12.2	12.2	Configuration	122
12.3	12.3	MIB mapping	123
13	13	gNMI/gRPC	127
13.1	13.1	Architecture	127
13.2	13.2	Build and Install	127
13.3	13.3	Starting clixon_grpc	128
13.4	13.4	Supported RPCs	128
13.5	13.5	Encodings	130
13.6	13.6	Limitations	130
14	14	YANG	131
14.1	14.1	Leafrefs	131
14.2	14.2	YANG Library	132
14.3	14.3	Extensions	133
14.4	14.4	Unique	135
14.5	14.5	If-feature and anydata	135
14.6	14.6	Schema mounts	136
15	15	Event notifications	141
15.1	15.1	Overview	141
15.2	15.2	Components	141
15.3	15.3	Main example	143
16	16	Usecases	145
16.1	16.1	CLI read	145
16.2	16.2	CLI write	146
16.3	16.3	Commit	147
16.4	16.4	RESTCONF RPC	148
17	17	XML	149
17.1	17.1	XML trees	149
17.2	17.2	Creating XML	151
17.3	17.3	Modifying XML	154
17.4	17.4	Searching in XML	156
17.5	17.5	Internal representation	160
17.6	17.6	Character encoding	161
18	18	Paths	163
18.1	18.1	XPaths	163
18.2	18.2	XPath API	164
18.3	18.3	Instance-identifier	168
18.4	18.4	Api-path	168

19	19	Pagination	171
19.1	19.1	Overview	171
19.2	19.2	Locked pagination	172
19.3	19.3	Pagination protocol	172
19.4	19.4	CLI scrolling	173
19.5	19.5	Backend pagination API	174
20	20	Upgrade	175
20.1	20.1	Options	175
20.2	20.2	General-purpose	175
20.3	20.3	Module-specific upgrade	176
20.4	20.4	Extra XML	178
20.5	20.5	Failsafe mode	179
20.6	20.6	Repair	179
20.7	20.7	Automatic upgrades	180
21	21	Errors and debug	183
21.1	21.1	Error reporting	183
21.2	21.2	Debugging	185
21.3	21.3	Customization	188
22	22	Misc	191
22.1	22.1	High availability	191
22.2	22.2	Process handling	191
22.3	22.3	Formats	193
22.4	22.4	Event handling	194

Clixon is a YANG-based configuration manager, with interactive CLI, NETCONF and RESTCONF interfaces, an embedded database and a transaction mechanism.

1 OVERVIEW

Clixon is a configuration management framework used by networking devices and other computer systems. Clixon provides a datastore, CLI, NETCONF and RESTCONF interfaces all defined by YANG.

Clixon links:

- [Source code at github.](#)
- [Project.](#)
- [Docs.](#)

Most of the projects using Clixon are for networking devices. But Clixon can be used for other YANG-based systems as well due to a modular and pluggable architecture.

Clixon has a transaction mechanism that ensures configuration operations are atomic. It also features a generated interactive command-line interface using [CLIGen](#).

The goal of Clixon is to provide a useful, production-grade, scalable and free YANG based configuration tool.

Clixon is open-source and dual licensed. Either Apache License, Version 2.0 or GNU General Public License Version 2.

1.1 1.1 System Architecture

Clixon provides YANG functionality with Netconf, Restconf and CLI that can be integrated with an existing “base system” in several ways. The integrations are:

- A *plugin* integration where clixon handles all user interaction with the base system using backend plugins. This is the `_primary_` Clixon usage model.
- A *client* integration where the base system uses clixon for configurations as a “side-car”. There is some ongoing work to make Clixon also work for this usage.

1.1.1 1.1.1 Plugin integration

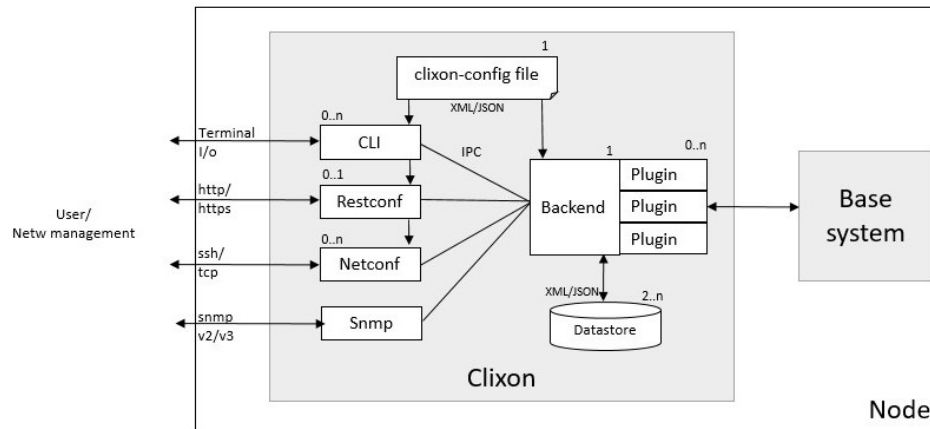

This describes how to integrate a base system with Clixon using plugins.

The Clixon architecture consists of a backend daemon with configuration datastores and a set of internal clients: cli, restconf, netconf and snmp.

The clients provide frontend interfaces to users of the system, such as a Network Management System (NMS) or an interactive human user. The external interfaces include interactive CLI, RESTCONF over HTTP/HTTPS, and XML NETCONF over TCP or SSH. Internally, the clients and backend communicate over an inter-process communication (IPC) bus via NETCONF over a UNIX socket. It is possible to run over an INET socket as well, but some authentication mechanisms are then disabled.

The backend manages configuration datastores and implements a transaction mechanism for configuration operations (eg, create, read, update, delete) . The datastore supports candidate, running and startup configurations.

A system integrating Clixon using plugins, typically starts with a set of YANG specifications. Backend plugins are written that interact with the base system. The plugins are written in C using the Clixon API and a set of plugin callbacks. The main callback is a transaction callback, where you specify how configuration changes are made to your system.

You can also design an interactive CLI using **CLIGen**, where you specify the CLI commands and write CLI plugins. You will have to write CLI rules, but Clixon can generate the configuration part of the CLI, including set, delete, show commands for a specific syntax.

Notifications (streams) are supported both for CLI, NETCONF and RESTCONF clients.

1.1.2 1.1.2 Client integration

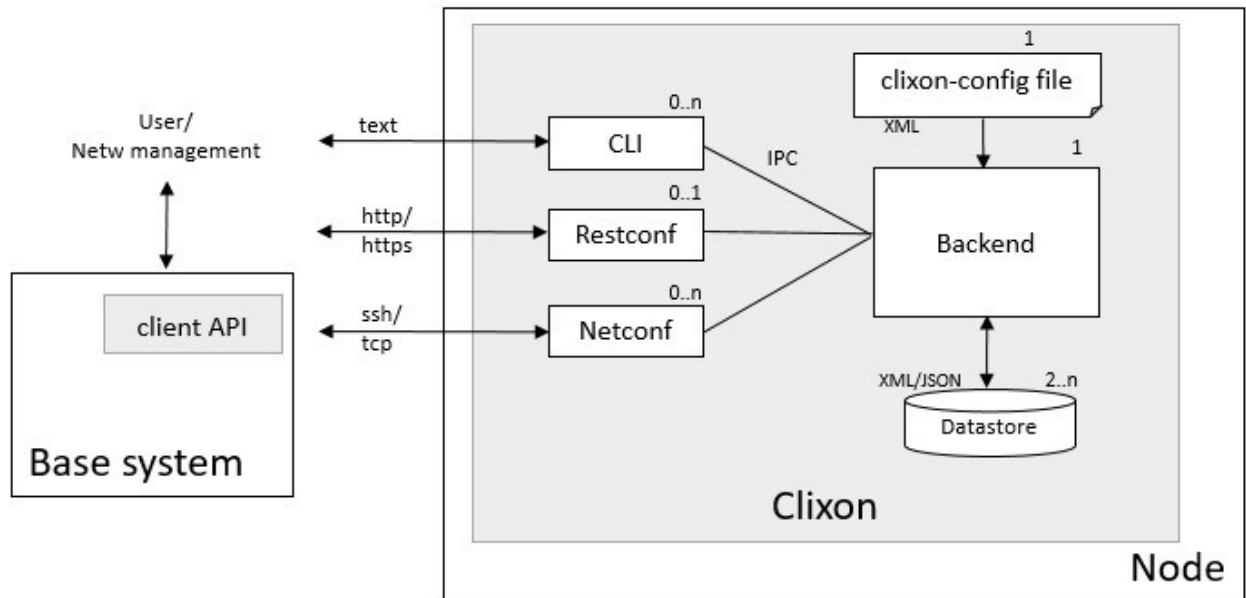

In a client architecture, the base system keeps existing APIs and only YANG-based configurations are exposed via Clixon. The base system acts as a clixon client and uses the clixon client module to subscribe to configuration events using Netconf message passing.

This model is not well documented.

1.2 1.2 Platforms

Clixon supports GNU/Linux, FreeBSD and Docker. MacOS may work. Linux platforms include Ubuntu, Alpine, Openwrt and Raspian. CPU architectures include x86_64, i686, and ARM.

1.3 1.3 Standards

Clixon supports standards including YANG, NETCONF, RESTCONF, XML and XPath. See *Standards section* for more details.

1.4 1.4 How to get Clixon

Get the Clixon source code from [Github](https://github.com/clixon/clixon.git):

```
git clone https://github.com/clixon/clixon.git
```

1.5 1.5 Support

Clixon interaction is best done posting issues, pull requests, or joining the Matrix clixon forum <https://matrix.to/#/#clixonforum:matrix.org>.

1.6 1.6 Bug reports

Report bugs via [Github issues](#)

1.7 1.7 Reference docs

The user-manual is this document. For reference documentation of the C-code, Doxygen is used. To build the reference documentation you need to check out the source code, and type `make doc`, eg:

```
git clone git@github.com:clixon/clixon.git
cd clixon
./configure
make doc
```

direct your browser to:

```
file:///<your home path>/clixon/doc/html/index.html
```

2 INSTALLATION

2.1 2.1 Ubuntu Linux

This section describes how to build Clixon from source on Ubuntu Linux. You can use this as a base for other platforms as well since many steps (such as prereqs) are similar.

Further, the *vagrant* scripts show how to build for some other Linux variants.

2.1.1 2.1.1 Prerequisites

General prerequisites

Install packages:

```
sudo apt-get install flex bison
```

Install and build CLigen:

```
git clone https://github.com/clixon/cligen.git
cd cligen;
configure
make;
sudo make install
```

Add a clixon user and group, using useradd and usermod:

```
sudo useradd -M -U clixon
sudo usermod -a -G clixon <youruser> # Remember to re-log in for this to take effect
sudo usermod -a -G clixon www-data # Only if RESTCONF
```

If you do not require RESTCONF, then continue with *Build clixon from source*.

RESTCONF HTTP Support

The RESTCONF implementation supports two HTTP configurations:

1. *Clixon native HTTP server*
2. *FastCGI for reverse proxy*

Clixon native HTTP server

Native http server requires openssl 1.1 or later.

Install TLS:

```
sudo apt-get install libssl-dev
```

Thereafter configure using default options:

```
configure
```

FastCGI for reverse proxy

FastCGI requires support for Nginx or similar reverse HTTP proxy:

```
sudo apt-get install nginx libfcgi-dev
```

Then, when building clixon from source (see below), configure clixon with:

```
configure --with-restconf=fcgi
```

Note that the libfcgi-dev package might not exist in Ubuntu 18 bionic or later, in which case need to build *fcgi* from source.

Note also that the ‘fcgi’ installation package might have a different name on other Linux distributions, such as “fcgi-dev” (alpine), “fcgi” (arch), “fcgi-devkit” (freebsd).

2.1.2 2.1.2 Build Clixon from source

Download clixon source code:

```
git clone https://github.com/clixon/clixon.git
```

Configure Clixon using one of the following RESTCONF configurations:

```
configure --with-restconf=native # clixon native HTTP server
configure --with-restconf=fcgi   # FastCGI support for reverse proxy, the default
                                # when no '--with-restconf' option is specified
configure --without-restconf     # Do not build restconf
```

For more configure options see: *Configure options*.

Build and install:

```
make                # Compile
sudo make install   # Install libs, binaries, config-files and include-files
sudo ldconfig       # To link new dynamic libraries
```

Building the example and utils

To build and install the example app, from the top level clixon directory:

```
make example
cd example
sudo make install
```

To build the utils for running the tests, from the top level clixon directory:

```
sudo apt install libcurl4-openssl-dev
cd util
make
sudo make install
```

See also the *Quickstart section* for building a complete *hello world* example.

2.2 2.2 FreeBSD

FreeBSD has ports for both cligen and clixon available. You can install them as binary packages, or you can build them in a ports source tree locally.

If you install using binary packages or build from the ports collection, the installation locations comply with FreeBSD standards and you have some assurance that the installed package is correct and functional.

The Nginx setup for RESTCONF is altered - the system user www is used, and the restconf daemon is placed in /usr/local/sbin.

2.2.1 2.2.1 Binary package install

To install the pre-built binary package, use the FreeBSD pkg command:

```
% pkg install clixon
```

This will install clixon and all the dependencies needed.

2.2.2 2.2.2 Build from source on FreeBSD

If you prefer you can also build clixon from the [FreeBSD ports collection](#)

Once you have the Ports Collection installed, you build clixon like this

```
% cd /usr/ports/devel/clixon
% make && make install
```

One issue with using the Ports Collection is that it may not install the latest version from GitHub. The port is generally updated soon after an official release, but there is still a lag between it and the master branch. The maintainer for the port tries to assure that the master branch will compile always, but no FreeBSD specific functional testing is done.

2.3 2.3 Systemd

Once installed, Clixon can be setup using systemd. The following shows an example with the backend and restconf daemons from the main example. Install them as `/etc/systemd/system/example.service` and `/etc/systemd/system/example_restconf.service`, for example.

2.3.1 2.3.1 Systemd backend

The backend service is installed at `/etc/systemd/system/example.service`, for example. Note that in this example, the backend installation requires the restconf service, which is not necessary.

```
[Unit]
Description=Starts and stops a clixon example service on this system
Wants=example_restconf.service
[Service]
Type=forking
User=root
RestartSec=60
Restart=on-failure
ExecStart=/usr/local/sbin/clixon_backend -s running -f /usr/local/etc/clixon/example.xml
[Install]
WantedBy=multi-user.target
```

2.3.2 2.3.2 Systemd restconf

The Restconf service can be installed at, for example, `/etc/systemd/system/example_restconf.service`:

```
[Unit]
Description=Starts and stops an example clixon restconf service on this system
Wants=example.service
After=example.service
[Service]
Type=simple
User=root
Restart=on-failure
ExecStart=/usr/local/sbin/clixon_restconf -f /usr/local/etc/clixon/example.xml
[Install]
WantedBy=multi-user.target
```

The restconf daemon can also be started internally using the clixon-lib process-control RPC. For more info, see *Restconf section*.

2.4 2.4 Docker

Clixon can run in a docker container. As an example the *docker* directory has boilerplate code for building Clixon in a container:

```
cd docker/base
make docker
```

For complete examples see:

- [Hello world](#)
- [Clixon CI test container](#)
- [Openconfig](#)

2.5 2.5 Vagrant

Clixon uses vagrant in testing. For example to start a Freebsd vagrant host, install Clixon and run the test suite, do

```
cd test/vagrant
./vagrant.sh generic/freebsd12
```

Other platforms include: [ubuntu/bionic64](#) and [generic/centos8](#). To look at how Clixon is installed natively on those platforms please look in the build scripts under [test/vagrant/](#).

2.6 2.6 OpenWRT

See [Clixon cross-compiler for Openwrt](#)

2.7 2.7 Prereqs from source

2.7.1 2.7.1 FCGI

For RESTCONF using fcgi build fcgi from source as follows:

```
git clone https://github.com/FastCGI-Archives/fcgi2
cd fcgi2
./autogen.sh
./configure --prefix=/usr
make
sudo make install
```

2.8 2.8 SSH subsystem

You can expose `clixon_netconf` as an SSH subsystem according to *RFC 6242*. Register the subsystem in `/etc/sshd_config`:

```
Subsystem netconf /usr/local/bin/clixon_netconf
```

and then invoke it from a client using:

```
ssh -s <host> netconf
```

2.9 2.9 Configure options

The Clixon `configure` script (generated by `autoconf`) includes several options apart from the standard ones.

These include (standard options are omitted)

- enable-debug** Build with debug symbols, default: no
- enable-yang-patch** Enable RFC 8072 YANG patch (plain patch is always enabled)
- enable-publish** Enable publish of notification streams using SSE and curl
- disable-http1** Disable native http/1.1 (ie http/2 only)
- disable-nhttp2** Disable native http/2 using libnhttp2 (ie http/1 only)
- with-cligen=dir** Use CLIGEN here
- with-restconf=native** RESTCONF using native http. (DEFAULT)
- with-restconf=fcgi** RESTCONF using fcgi/ reverse proxy.
- without-restconf** No RESTCONF
- with-configfile=FILE** Set default path to config file
- with-libxml2** Use gnome/libxml2 regex engine
- without-sigaction** Disable sigaction logic (some platforms do not support SA_RESTART mode)
- with-yang-installdir=DIR** Install Clixon yang files here (default: `${prefix}/share/clixon`)
- with-yang-standard-dir=DIR** Location of standard IETF/IEEE YANG specs for tests and example (default: `$prefix/share/yang/standard`). You can retrieve the standard files at <https://github.com/YangModels/yang>
- with-clicon-user=user** Run as this user in example and test
- with-clicon-group=group** Run as this group in example and test

There are also some variables that can be set, such as:

```
./configure LINKAGE=static # Build static libraries
./configure CFLAGS="-O1 -Wall" INSTALLFLAGS="" # Use other CFLAGS
```

Note, you need to reconfigure and recompile from scratch if you want to build static libs

2.10 2.10 macOS

Clixon can be built on macOS, however not all tests will pass at this moment and there might be pieces which will not run properly.

A few packages must be installed using for example HomeBrew:

```
brew install openssl nghttp2
```

Since we install a few libraries from HomeBrew we might want to set C and library paths:

```
$ export LIBRARY_PATH=$LIBRARY_PATH:/opt/homebrew/opt/openssl/lib  
$ export C_INCLUDE_PATH=/opt/homebrew/opt/openssl/include/
```

Then Cligen and Clixon can be built as normal. Since Clixon will install things in “/usr/local/sbin/” you might want to add this to PATH. Either temporarily using:

```
export PATH=$PATH:/usr/local/sbin/
```

Or permanently by adding the above to .bash_profile or similar.

Since macOS don't use systemd or similar you'll have to start and stop clixon_backend etc manually.

3 QUICK START

This section describes how to run the *hello world* example available in source code at: [clixon hello example](#).

Clixon is not a system in itself, it is a support system for an application. In this case, the “application” is hello world. The hello world application is very simple where the application semantics is completely described by a YANG and CLI specification.

A more advanced application have backend and frontend plugins that define application-specific semantics. No plugins are present in the hello world application.

The hello world example can be run both natively on the host and in a docker container.

3.1 3.1 Host native

3.1.1 3.1.1 Clixon

Go through the *install instructions* to install Clixon on your platform. This includes installing CLlgen, Clixon, creating users, groups, etc.

In short:

```
git clone https://github.com/clixon/cligen.git
cd cligen
./configure
make && sudo make install
git clone https://github.com/clixon/clixon.git
cd clixon
./configure
make && sudo make install
```

Then proceed with host application install.

3.1.2 3.1.2 Files

Files relevant to the hello world example are:

- `hello.xml`: the XML configuration file
- `clixon-hello@2019-04-17.yang`: the YANG spec
- `hello_cli.cli`: the CLIGen spec
- `startup_db`: The startup datastore containing restconf port configuration
- `Makefile`: install of specs, normally compile of plugins

3.1.3 3.1.3 Install and run

Checkout and configure the examples on the top-level:

```
git clone https://github.com/clixon/clixon-examples.git
cd clixon-examples
./configure
```

Compile and install:

```
cd hello/src
make && sudo make install
```

Start backend in the background:

```
sudo clixon_backend
```

Start cli:

```
clixon_cli
```

3.2 3.2 Using the CLI

The example CLI allows you to modify and view the data model using *set*, *delete* and *show* via generated code.

The following example shows how to add a very simple configuration *hello world* using the generated CLI. The config is added to the candidate database, shown, committed to running, and then deleted.

```
olof@vandal> clixon_cli
cli> set <?>
  hello
cli> set hello world
cli> show configuration
hello world;
cli> commit
cli> delete <?>
  all                Delete whole candidate configuration
  hello
cli> delete hello
cli> show configuration
```

(continues on next page)

(continued from previous page)

```
cli> commit
cli> quit
olof@vandal>
```

3.3 3.3 Netconf

Clixon also provides a Netconf interface. The following example starts a netconf client from the shell vi stdio, adds the hello world config, commits it, and shows it:

```
olof@vandal> clixon_netconf -q
<?xml version="1.0" encoding="UTF-8"?>
<hello xmlns="urn:ietf:params:xml:ns:netconf:base:1.0"><capabilities><capability>
↪urn:ietf:params:netconf:base:1.1</capability></capabilities></hello>]]>]]>
<rpc xmlns="urn:ietf:params:xml:ns:netconf:base:1.0"><edit-config><target><candidate/></
↪target><config><hello xmlns="urn:example:hello"><world/></hello></config></edit-config>
↪</rpc>]]>]]>
<rpc-reply xmlns="urn:ietf:params:xml:ns:netconf:base:1.0"><ok/></rpc-reply>]]>]]>
<rpc xmlns="urn:ietf:params:xml:ns:netconf:base:1.0"><commit/></rpc>]]>]]>
<rpc-reply xmlns="urn:ietf:params:xml:ns:netconf:base:1.0"><ok/></rpc-reply>]]>]]>
<rpc xmlns="urn:ietf:params:xml:ns:netconf:base:1.0"><get-config><source><running/></
↪source></get-config></rpc>]]>]]>
<rpc-reply xmlns="urn:ietf:params:xml:ns:netconf:base:1.0"><data><hello xmlns=
↪"urn:example:hello"><world/></hello></data></rpc-reply>]]>]]>
olof@vandal>
```

3.4 3.4 Restconf

By default, Clixon uses *Native http*: supporting http/1 and http/2 (libnghttp2). The http server is integrated with the clixon restconf daemon and needs no extra installations, apart from ensuring you have server and client certs for https.

As an alternative, you can use the *FCGI* solution, where instead a reverse proxy such as [Nginx](#) uses an internal FCGI socket communication to communicate with Clixon. A reverse proxy, such as NGINX, needs to be configured. For more info about the fcgi solution, see *Restconf section*.

3.4.1 3.4.1 Start and run

Regardless of which RESTCONF variant is used, start the restconf daemon as follows:

```
sudo clixon_restconf
```

Start sending restconf commands (using Curl):

```
olof@vandal> curl -X POST http://localhost/restconf/data -d '{"clixon-hello:hello":{
↪"world":null}}'
olof@vandal> curl -X GET http://localhost/restconf/data
{
  "data": {
    "clixon-hello:hello": {
```

(continues on next page)

(continued from previous page)

```

    "world": null
  }
}
}

```

3.5 3.5 Docker container

You can run the hello example as a pre-built docker container, on a *x86_64* Linux. See instructions in the [clixon docker hello example](#).

First, the container is started with the backend running:

```
$ sudo docker run --rm -p 8080:80 --name hello -d clixon/hello
```

Then a CLI is started

```

$ sudo docker exec -it hello clixon_cli
cli> set ?
hello
cli> set hello world
cli> show configuration
hello world;

```

Or Netconf:

```

$ sudo docker exec -it clixon/clixon clixon_netconf
<?xml version="1.0" encoding="UTF-8"?>
<hello xmlns="urn:ietf:params:xml:ns:netconf:base:1.0"><capabilities><capability>
↪urn:ietf:params:netconf:base:1.1</capability></capabilities></hello>]]>]]>
<rpc xmlns="urn:ietf:params:xml:ns:netconf:base:1.0"><get-config><source><candidate/></
↪source></get-config></rpc>]]>]]>
<rpc-reply xmlns="urn:ietf:params:xml:ns:netconf:base:1.0"><data/></rpc-reply>]]>]]>

```

Or using restconf using curl on exposed port 8080:

```
$ curl -X GET http://localhost:8080/restconf/data/hello:system
```

3.6 3.6 Next steps

The hello world example only has a Yang spec and a template CLI spec. For more advanced applications, customized backend, CLI, netconf and restconf code callbacks becomes necessary.

Further, you may want to add upgrade, RPC:s, state data, notification streams, authentication and authorization. The [main example](#) contains such capabilities.

4 STANDARDS

4.1 4.1 YANG

YANG and XML are central to Clixon. Yang modules are used as a specification for encoding XML or JSON configuration and state data. The YANG spec is also used to generate an interactive CLI, NETCONF and RESTCONF clients, as well as the format of the XML datastore.

The YANG standards that Clixon follows include (see also *netconf*):

- YANG 1.0 RFC 6020
- YANG 1.1 RFC 7950
- YANG library RFC 8525 (partly)

Clixon deviates from the YANG standard as follows (reference to RFC7950 sections in parenthesis):

Not implemented:

- instance-identifier type (9.13)
- status (7.21.2)
- YIN (13)
- error-message is not implemented as sub-statement of “range”, “length” and “pattern”
- quoted string concatenation using + for other than the “string” non.-terminal (eg identifier-args)

Clixon supports the following extended XPath functions (10):

- current()
- re-match()
- deref()
- derived-from(),
- derived-from-or-self()
- bit-is-set()

The following extended XPath function is *not* supported (10):

- enum-value()

See also support of standard XPath functions *XML and XPath*

4.1.1 4.1.1 Regular expressions

Clixon supports two regular expression engines:

Posix

The default method, The regexps:s are translated to posix before matching with the standard Linux regex engine. This translation is not complete but can be considered “good-enough” for most yang use-cases. For reference, all standard [Yang models](#) have been tested.

Libxml2

Libxml2 uses the XSD regex engine. This is a complete XSD engine but you need to compile and link with libxml2 which may add overhead.

To use libxml2 in clixon you need enable libxml2 in both cligen and clixon:

```
./configure --with-libxml2 # both cligen and clixon
```

You then need to set the following configure option:

```
<CLICON_YANG_REGEX>libxml2</CLICON_YANG_REGEX>
```

4.1.2 4.1.2 Metadata

Clixon implements [Defining and Using Metadata with YANG RFC 7952](#) for XML and JSON.

This means that Yang-derived meta-data defined with:

```
md:annotation <name>
```

is defined for attributes so that they can be mapped from XML to JSON, for example.

Assigned meta-data are hardcoded. The following attributes are defined:

- ietf-netconf-with-defaults:default from RFC 6243 / RFC 8040

4.1.3 4.1.3 Schema mount

Yang schema mount is supported as defined in: [RFC 8528: YANG Schema Mount](#) .

Enable by the `CLICON_YANG_SCHEMA_MOUNT` configuration option.

4.2 4.2 NETCONF

Clixon implements the following NETCONF RFC:s:

- [RFC 5277: NETCONF Event Notifications](#)
- [RFC 6022: YANG Module for NETCONF Monitoring.](#)
- [RFC 6241: NETCONF Configuration Protocol](#)
- [RFC 6242: Using the NETCONF Configuration Protocol over Secure Shell \(SSH\)](#)
- [RFC 6243 With-defaults Capability for NETCONF](#)
- [RFC 8071: NETCONF Call Home and RESTCONF Call Home.](#) NETCONF over SSH (external) and RESTCONF call home (internal) over TLS are implemented.

- RFC 8341: Network Configuration Access Control Model (NACM). Notification not implemented.
- RFC 9144: Comparison of Network Management Datastore Architecture (NMDA) Datastores. all, report-origin, subtree-filter not implemented

The following RFC6241 capabilities/features are hardcoded in Clixon:

- :candidate (RFC6241 8.3)
- :validate (RFC6241 8.6)
- :xpath (RFC6241 8.9)
- :notification (RFC5277)
- :with-defaults (RFC6243)

The following features are optional and can be enabled by setting CLICON_FEATURE:

- :confirmed-commit:1.1 (RFC6241 8.4)
- :startup (RFC6241 8.7)
- :writable-running (RFC6241 8.2) - just write to running, no commit semantics

Clixon does *not* support the following NETCONF features:

- :url capability
- copy-config source config
- edit-config testopts
- edit-config erropts
- edit-config config-text
- edit-config operation

Further, in *get-config* filter expressions, the RFC6241 XPath Capability is preferred over default subtrees. This has two reasons:

1. XPath has better performance since the underlying system uses xpath, and subtree filtering is done after the complete tree is retrieved.
2. Subtree filtering does not support namespaces.

Clixon supports netconf locks in default settings.

4.2.1 RFC 6022 YANG Module for NETCONF Monitoring

Clixon extends the RFC 6022 session parameter `transport` with “cli”, “restconf”, “netconf” and “snmp”. In particular, the `clixon_netconf` application uses `stdio` to get input and print output and is used in a “piping” fashion, for example directly in a terminal shell or as a part of a SSH sub-system, and therefore has no direct knowledge of whether the NETCONF transport is over SSH or not.

The `source-host` parameter is set only in certain circumstances when the source host is in fact known. This includes native RESTCONF for example.

Further, `hello` counters are backend based, ie the internal protocol, which means hellos from RESTCONF, SNMP and CLI clients are included and that eventual dropped hello messages from external NETCONF sessions are not.

4.2.2 4.2.2 Default handling

Clixon treats default data according to what is defined as *explicit basic mode* in RFC 6243: [With-defaults Capability for NETCONF](#), i.e. the server considers any data node that is not explicitly set data to be default data.

One effect is that if you view the contents of datastores (or import/export them), they should be in *explicit basic mode*.

The `:with-defaults` capability indicates that clixon default behaviour is explicit and also indicates that additional retrieval modes supported by the server are:

- explicit
- trim
- report-all
- report-all-tagged

Internally in memory, however, *report-all* is used.

4.2.3 4.2.3 Private candidate

Clixon implements private candidate as defined in NETCONF and RESTCONF [Private Candidate Datastores](#) with the following restrictions:

- `revert-on-conflict` is the only resolution mode supported
- No augments on *compare* operation
- Leaf-list conflict resolution fine-grained as opposed to draft
- Delete candidate on commit (draft is unclear)
- `<delete-config>` is not possible on candidate configuration (draft vs RFC6241)
- `<get-data>` and `<edit-data>` is not supported by Clixon (RFC8526)
- Clixon fulfils RFC6241 regarding confirmed commit, but not draft proposal on immediate revert of unconfirmed configuration if session disconnects.

4.3 4.3 RESTCONF

Clixon supports the two RESTCONF compile-time variants: *FCGI* and *Native*. Both implements RFC 8040: [RESTCONF Protocol](#).

The following features of RFC8040 are supported:

- OPTIONS, HEAD, GET, POST, PUT, DELETE, PATCH
- Stream notifications (Sec 6)
- Query parameters: *insert*, *point*, *content*, *depth*, *start-time*, *stop-time*, *with-defaults* and *fields* (root only)
- Monitoring (Sec 9)

The following features are *not* implemented:

- ETag/Last-Modified
- Query parameters: *filter*

RESTCONF event notification as described in RFC7950 section 6 is supported as follows:

- Limited to regular subscription, start-time and stop-time

NMDA is partly supported according to [RFC 8324](#) and [RFC 8527](#). *With-defaults* and *with-origin* are not implemented. [RFC 8072: YANG Patch Media Type](#) is not implemented.

In the native mode, Clixon also supports:

- HTTP/1.1 as transport using a native implementation ([RFC 7230](#)),
- HTTP/2 as transport implemented by `libnghttp2` ([RFC7540](#)),
- Transport Layer Security (TLS) implemented by `libopenssl`, versions 1.1.1 and 3.0
- ALPN as defined in [RFC 7301](#) for `http/1`, `http/2` protocol selection by `libopenssl`

4.4 4.4 SNMP

The Clixon-SNMP frontend implements the MIB-YANG mapping as defined in [RFC 6643](#).

4.5 4.5 XML and XPath

Clixon has its own implementation of XML and XPath. See more in the detailed API reference.

The XML-related standards include:

- [XML 1.0](#). (DOCTYPE/ DTD not supported)
- [Namespaces in XML 1.0](#)
- [XPath 1.0](#)

Clixon XML supports version and UTF-8 only.

The following XPath axes are supported:

- `child`,
- `descendant`,
- `descendant-or-self`,
- `self`
- `parent`

The following xpath axes are *not* supported:

- `preceding`
- `preceding_sibling`
- `namespace`
- `following_sibling`
- `following`
- `ancestor`
- `ancestor_or_self`
- `attribute`

The following XPath functions as defined in Section 2.3 / 4 of the XPath 1.0 standard are supported:

- position
- count
- local-name
- name
- string
- concat
- starts-with
- contains
- substring-before
- substring-after
- substring
- string-length
- translate
- boolean
- not
- true
- false
- number
- text
- node

The following standard XPath functions are *not* supported:

- ceiling
- comment
- floor
- id
- lang
- last
- namespace-uri
- normalize-space
- processing-instructions
- round
- sum

4.6 4.6 Pagination

The pagination solution is based on the following drafts:

- <https://www.ietf.org/archive/id/draft-ietf-netconf-list-pagination-07.html>
- <https://www.ietf.org/archive/id/draft-ietf-netconf-list-pagination-nc-07.html>
- <https://www.ietf.org/archive/id/draft-ietf-netconf-list-pagination-rc-07.html>

Clixon implements all attributes except *cursor*, *locale*, *sublist-limit* and *remaining*.

See *Pagination section* for more info.

4.7 4.7 Unicode

Unicode is not supported in YANG and XML.

4.8 4.8 JSON

Clixon implements JSON according to:

- ECMA JSON Data Interchange Syntax
- RFC 7951 JSON Encoding of Data Modeled with YANG.
- RFC 8259 The JavaScript Object Notation (JSON) Data Interchange Format

4.9 4.9 gRPC/gNMI

Clixon introduces a first preliminary gRPC/gNMI interface in version 7.8 according to: <https://openconfig.net/docs/gnmi/gnmi-specification>.

Features include:

- nhttp2 server, gRPC framing, trailers
- Capabilities, returns loaded YANG modules + encodings (JSON_IETF, JSON, ASCII)
- Get(XPath handling, namespace handling),
- Set(update/replace/delete)
- Subscribe RPC (ONCE)
- Module qualified names, unqualified node fallback
- Bool, double, ascii typed values

Limitations include:

- TLS (high prio)
- NACM (depends on TLS)
- Set leaf-list Set
- Subscribe RPC (STREAM/POLL)

- Notifications
- Mount-point support

5 CONFIGURATION

Clixon configuration files are encoded in XML and modeled by YANG. By default, the main config file is installed as `/usr/local/etc/clixon.xml`, but can be changed by the `-f <file>` command-line option.

The YANG specification for Clixon configuration is `clixon-config.yang`. This configuration file is updated regularly.

Normally, all Clixon processes (backend, cli, netconf, restconf) use the same configuration, although some options are not valid for all processes. You can however have different configuration files for different clients by using the `-f` option.

Loading an obsolete config option will result in an error.

Please consult the `clixon-config YANG spec` directly if you want detailed description of config options.

5.1 5.1 Example

The following is the configuration file of a simple example:

```
<clixon-config xmlns="http://clixon.org/config">
  <CLICON_CONFIGFILE>/usr/local/etc/clixon.xml</CLICON_CONFIGFILE>
  <CLICON_CONFIGDIR>/usr/local/etc/clixon.d</CLICON_CONFIGDIR>
  <CLICON_FEATURE>*:*</CLICON_FEATURE>
  <CLICON_YANG_DIR>/usr/local/share/clixon</CLICON_YANG_DIR>
  <CLICON_YANG_MODULE_MAIN>clixon-hello</CLICON_YANG_MODULE_MAIN>
  <CLICON_CLI_MODE>hello</CLICON_CLI_MODE>
  <CLICON_CLISPEC_DIR>/usr/local/lib/hello/clispec</CLICON_CLISPEC_DIR>
  <CLICON_SOCK>/usr/local/var/hello.sock</CLICON_SOCK>
  <CLICON_BACKEND_PIDFILE>/usr/local/var/hello.pidfile</CLICON_BACKEND_PIDFILE>
  <CLICON_XMLDB_DIR>/usr/local/var/hello</CLICON_XMLDB_DIR>
  <CLICON_STARTUP_MODE>init</CLICON_STARTUP_MODE>
  <restconf>
    <enable>true</enable>
  </restconf>
</clixon-config>
```

The option `CLICON_CONFIGFILE` is special, it must be available before the configuration file is found (see *Loading the configuration*), which means that the value in the file is a no-op.

The `restconf` clause defines RESTCONF configuration options as described in the *restconf section*.

5.2 5.2 Loading the configuration

Clixon finds its configuration files, according to the following method:

1. Start a clixon program with the `-f <FILE>` option. For example:

```
clixon_backend -f FILE
```

2. At install time, Use the `--with-configfile=FILE` option to configure a default location:

```
./configure --with-configfile=FILE
```

3. At install time: `./configure --with-sysconfig=<dir>` when configuring. Then FILE is `<dir>/clixon.xml`
4. At install time: `./configure --sysconfig=<dir>` when configuring. Then FILE is `<dir>/etc/clixon.xml`
5. If none of the above: FILE is `/usr/local/etc/clixon.xml`

The following options control the Clixon configuration:

CLICON_CONFIGFILE

The configure file itself. Due to bootstrapping reasons, its value is meaningless in a file but can be useful for documentation purposes.

CLICON_CONFIGDIR

A directory of extra configuration files loaded after the main configuration. It can also be specified using the `-E <dir>` command-line option. These extra configuration files are read in alphabetical order after the main configuration as follows:

- leaf values are overwritten
- leaf-list values are appended

5.3 5.3 Runtime modification

You can modify clixon options at runtime by using the `-o` option to modify the configuration specified in the configuration file. For example, add `usr/local/share/ietf` to the list of directories where yang files are searched for:

```
clixon_cli -o CLICON_YANG_DIR=/usr/local/share/ietf
```

5.4 5.4 Features

CLICON_FEATURE is a list of values, describing how Clixon supports features.

A value is specified as one of the following:

- `<module>:<feature>` : enable a specific feature in a specific module
- `*:*` : enable all features in all modules
- `<module>:*` : enable all features in the specified module
- `*:<feature>` : enable the specific feature in all modules.

Example:

```
<CLICON_FEATURE>ietf-netconf:startup</CLICON_FEATURE>
<CLICON_FEATURE>ietf-netconf:*</CLICON_FEATURE>
<CLICON_FEATURE>*:*</CLICON_FEATURE>
```

Supplying the `-o` option adds a value to the feature list.

Clixon have three hardcoded features:

- `ietf-netconf:candidate` (RFC6241 8.3)
- `ietf-netconf:validate` (RFC6241 8.6)
- `ietf-netconf:xpath` (RFC6241 8.9)

5.5 5.5 Finding YANG files

The example have two options for finding Yang files:

```
<CLICON_YANG_DIR>/usr/local/share/clixon</CLICON_YANG_DIR>
<CLICON_YANG_MODULE_MAIN>clixon-hello</CLICON_YANG_MODULE_MAIN>
```

which means that Yang files are searched for in `/usr/local/share/clixon` and that module `clixon-hello` is loaded. Note:

- `clixon-hello.yang` must be present in `/usr/local/share/clixon`
- Clixon itself may load several YANG files as part of the system startup, such as `clixon-config.yang`. These must all reside in the list of `CLICON_YANG_DIR:s`.
- When a Yang file is loaded, it may contain references to other Yang files (eg using `import` and `include`). They must also be found in the list of `CLICON_YANG_DIR:s`.

The following configuration file options control the loading of Yang files:

CLICON_YANG_DIR

A list of directories (yang dir path) where Clixon searches for module and submodules *recursively*.

CLICON_YANG_MAIN_FILE

Load a specific Yang module given by a file.

CLICON_YANG_MODULE_MAIN

Specifies a single module to load. The module is searched for in the yang dir path.

CLICON_YANG_MODULE_REVISION

Specifies a revision to the main module.

CLICON_YANG_MAIN_DIR

Load all yang modules in this directory, not recursively.

Note that the special `YANG_INSTALLDIR` autoconf configure option, by default `/usr/local/share/clixon` should be included in the yang dir path for Clixon system files to be found.

You can combine the options, however, if there are different variants of the same module, more specific options override less specific. The precedence of the options are as follows:

1. `CLICON_YANG_MAIN_FILE`
2. `CLICON_YANG_MODULE_MAIN`
3. `CLICON_YANG_MAIN_DIR`

Note that using CLICON YANG_MAIN_DIR Clixon may find several files containing the same Yang module. Clixon will prefer the one without a revision date if such a file exists. If no file has a revision date, Clixon will prefer the newest.

5.6 5.6 Standard YANG files

The main examples and tests require IETF RFC standard YANGs. If you want to run the main example or run tests, you need to make them locally available by checking out <https://github.com/YangModels/yang> which has subdirectory standard. By default this directory is `/usr/local/share/yang`. You can change this location by:

```
./configure --with-yang-standard-dir=DIR
```

Note that you do not need this for the clixon runtime.

5.7 5.7 Extending the configuration

You can extend the options with an application-specific YANG file where you augment the regular “clixon-config” as follows:

```
<clixon-config xmlns="http://clixon.org/config">
  <CLICON_CONFIGFILE>/usr/local/etc/clixon.xml</CLICON_CONFIGFILE>
  <CLICON_CONFIG_EXTEND>clixon-myconfig</CLICON_CONFIG_EXTEND>
  ...
```

You then install your own “clixon-myconfig.yang” where you add your own config options. Example:

```
module clixon-myconfig {
  yang-version 1.1;
  namespace "http://example.org/myconfig";
  ...
  import clixon-config {
    prefix "cc";
  }
  augment "/cc:clixon-config" {
    description
      "My extended options";
    leaf MYOPT {
      type string;
    }
  }
}
```

You can now use your extended options in the regular config file, along with the basic ones, but with another namespace:

```
<clixon-config xmlns="http://clixon.org/config">
  <CLICON_CONFIGFILE>/usr/local/etc/clixon.xml</CLICON_CONFIGFILE>
  <CLICON_CONFIG_EXTEND>clixon-myconfig</CLICON_CONFIG_EXTEND>
  ...
  <MYOPT xmlns="http://example.org/myconfig">/usr/local/share/myopt</MYOPT>
```

You can also use the regular C-API to access the values of the options, eg:

```
char *val = clixon_option_str(h, "MYOPT");
```

6 PLUGINS

Plugins are the “glue” that binds the underlying system to Clixon and where application semantics is added by an application developer.

The backend, CLI, Restconf and Netconf applications may use plugins, although the main use of plugins are the *Backend section* plugins.

Plugins are written in C as dynamically loaded modules (.so files). At startup, the application looks in the assigned directory and loads all files with .so suffixes from that dir in *alphabetical* order.

Plugins are located as follows:

- Backend plugins are in CLICON_BACKEND_DIR
- CLI plugins are in CLICON_CLI_DIR
- NETCONF plugins are in CLICON_NETCONF_DIR
- RESTCONF plugins are in CLICON_CLI_DIR;

For example, to load all backend plugins from: /usr/local/lib/example/backend:

```
<CLICON_BACKEND_DIR>/usr/local/lib/example/backend</CLICON_BACKEND_DIR>
```

Callbacks are registered in two ways:

- *clixon_plugin_init* : Return an API struct containing a fixed set of callbacks
- *register functions* : Register callback functions for more complex interaction

Further, CLI callbacks as described in *CLI section* are special in the way that they are invoked from CLIGen specifications, not from the application itself.

6.1 6.1 Clixon_plugin_init

On startup, the application loads each plugin and calls `clixon_plugin_init` in that plugin. The function is expected to return an API struct `clixon_plugin_api` defining a set of static callbacks. The init function may return NULL in which case it is logged and ignored.

Once the plugin is loaded, it awaits callbacks from the application.

An example of a minimal plugin is as follows:

```
static clixon_plugin_api api = {  
    "example",                /* Plugin name */  
    clixon_plugin_init,      /* init - must be called clixon_plugin_init */  
};
```

(continues on next page)

(continued from previous page)

```

example_start,          /* start */
example_exit,          /* exit */
example_extension,     /* yang extensions */
.ca_daemon=example_daemon, /* Plugin daemonized () (backend only) */
};

clixon_plugin_api *
clixon_plugin_init(clixon_handle h)
{
    return &api;
}

```

First the `clixon_plugin_api` struct defines the callbacks. There are two blocks of callbacks:

- Common callbacks for backend, cli, netconf, and restconf
- Application-specific callbacks. In the example, only `ca_daemon` is specific to backends. By far, the backend have most specific callbacks.

Second, the `clixon_plugin_init()` function is defined and (at a minimum) returns the struct.

The following callbacks are common plugins for all Clixon applications:

init

Clixon plugin init function, called immediately after plugin is loaded into the application. The name of the function must be called `clixon_plugin_init`. It returns a struct with the name of the plugin, and all other callback names.

start

Called when application is started and initialization is complete, but before the application is placed in the background and privileges are dropped (if applicable)

exit

Called just before plugin is unloaded at exit

extension

Called at parsing of yang modules containing an extension statement. A plugin may identify the extension by its name, and perform actions on the yang statement, such as transforming the yang in-memory. A callback is made for every statement, which means that several calls per extension can be made. See *Misc section* and the main example on how to use extensions.

yang_mount

Called when populating a RFC8525 mount-point. See *YANG section* for more info.

yang_patch

Patch a yang module. This may be necessary with an imported faulty or non-compliant YANG module

errmsg

Customize a netconf error message for CLI return, log or debug messages. See *Error section* and the main example.

version

Print a plugin-specific version string

userdef

User-defined callback which can be used by an application as special-purpose callback

See *Backend section* for backend specific callbacks, as well as corresponding manual sections for netconf/restconf/cli callbacks.

6.2 6.2 Registered callbacks

A second group of callbacks use register functions. This is a more detailed mechanism than the fixed callbacks described previously, but are only defined to a limited sets of functions:

- `rpc_callback_register()` - for user-defined RPC callbacks. Applicable for NETCONF, RESTCONF and backend.
- `action_callback_register()` - for user-defined Action callbacks. Applicable for backend.
- `upgrade_callback_register()` - for upgrading, see *Upgrade section*. Applicable only for backend.
- `clixon_pagination_cb_register()` - for pagination, as described in *Pagination section*. Applicable only for backend.

A user may register may register a callback for an incoming RPC, and that function will be called.

There may be several callbacks for the same RPC. The order the callbacks are registered are as follows:

1. `plugin_init`
2. `backend_rpc_init` (where system callbacks are registered)
3. `plugin_start`

Which means if you register a copy-config callback in (1), it will be called *before* the system copy-config callback registered from (2) `backend_rpc_init`. If you register a copy-config in (3) `plugin-start` it will be called *after* the system copy-config.

Second, if there are more than one reply (eg `<rpc-reply/><rpc-reply/>`) only the first reply will be parsed and used by the cli/netconf/restconf clients.

If you want to take the original and modify it, you should therefore register the callback in `plugin_start` (3) so that your callback will be called after the system RPC. Then you should modify the original reply (not add a new reply).

6.2.1 6.2.1 Example: RPC callback

This example shows how to define a new RPC in YANG for the backend, register a callback function in C, read and write a parameter. It is revised slightly from the main example.

YANG:

```
module clixon-example {
  namespace "urn:example:clixon";
  ...
  rpc example {
    input {
      leaf x {
        type string;
        ...
      }
    }
    output {
      leaf y {
        type string;
        ...
      }
    }
  }
}
```

Register RPC in `clixon_plugin_init()`:

```

clixon_plugin_api *clixon_plugin_init(clixon_handle h)
{
    ...
    rpc_callback_register(h, example_rpc, NULL, "urn:example:clixon", "example");
}

```

Callback function reading value input x, modifying value and writing it as output value y:

```

static int
example_rpc(clixon_handle h,          /* Clixon handle */
            cxobj      *xe,          /* Request: <rpc><xn></rpc> */
            cbuf      *cbret,       /* Reply eg <rpc-reply>... */
            void      *arg,         /* client_entry */
            void      *regarg)      /* Argument given at register */
{
    char *val;
    val = xml_find_body(xe, "x");    /* Read x value of incoming rpc */
    cprintf(cbret, "<rpc-reply xmlns=\"%s\">", NETCONF_BASE_NAMESPACE);
    val[0]++;                        /* Increment first char */
    /* Construct reply */
    cprintf(cbret, "<y xmlns=\"%urn:example:clixon\">%s</y>", val);
    cprintf(cbret, "</rpc-reply>");
}

```

Result netconf session:

```

<rpc xmlns="urn:ietf:params:xml:ns:netconf:base:1.0" message-id="42">
  <example xmlns="urn:example:clixon">
    <x>42</x>
  </example>
</rpc>]]>]]>
<rpc-reply xmlns="urn:ietf:params:xml:ns:netconf:base:1.0" message-id="42">
  <y xmlns="urn:example:clixon">52</y>
</rpc-reply>]]>]]>

```

6.2.2 Example: Action callback

This example follows RFC 7950 7.15.3.

An action is associated with a YANG node and can therefore not be registered at init, instead the start callback can be used, for example.

Register Action in example_reset():

```

int
example_start(clixon_handle h)
{
    ...
    if (action_callback_register(h, ya, example_action_reset, NULL) < 0)
        goto done;
}

```

6.3 6.3 Reporting RPC errors

Some YANG specifications require specific RPC errors to be returned for specific issues. The user may want to control errors returned by a transaction, in general. To do this, use the `clixon_plugin_rpc_err()` function and return a -1 from the function:

```
clixon_plugin_rpc_err(h, namespace, type, tag, info, severity, format, ...)
```

where: * *h* is a `clixon_handle`. * *ns* is the namespace. If you pass in NULL, it will use the NETCONF base namespace. * *type* is the error type, one of `rpc`, `application` or `protocol`. * *tag* is an error tag, like `invalid-value` and the YANG specification will tell you what to put here. * *info* is protocol or application specific. It may be NULL and will not be included in that case. * *severity* is one of `error` or `warning`. * *format* specifies a normal printf-like format for a string that will be put into the error-message field for the rpc error.

The specific values for all these are defined in *RFC 6241: NETCONF Protocol* <<http://www.rfc-editor.org/rfc/rfc6241.txt>> in the *rpc-error* section.

This is much like `clixon_err()` as defined in *Error section*, except you can set the namespace, type, tag, info, severity, etc.

6.4 6.4 Plugin callback guidelines

Note: This information is important to understand for the stability of clixon

The Clixon programs run as non-blocking *single-threaded* applications. It calls functions from within dynamically loaded modules. The callback code must be written with this programming model in mind. The behavior of the callback directly impacts the behavior of the caller and the whole system.

The most serious effect is when crash within a callback happens. This will cause the whole program to crash.

A more subtle problem is the environment of the program. Clixon will configure the environment, and it expects that the callback will return with the exact same environment intact. If you change a signal handler, a terminal configuration, etc. *you must restore the state as it was on entry*. Failure to do this can cause problems that are difficult to isolate and fix.

A list of things to watch out for (but not complete!):

- a crash in the plugin
- change of signal behaviour, such as blocking or assigning signal handlers
- change of terminal settings (for CLI callbacks)
- change of process privileges
- asynchronous calls
- If you fork or create threads, ensure the main program continues uninterrupted

The following config option is related to checking callbacks:

CLICON_PLUGIN_CALLBACK_CHECK

Enable check of resources before and after each callback. Checks are currently limited to signal and terminal settings

7 BACKEND

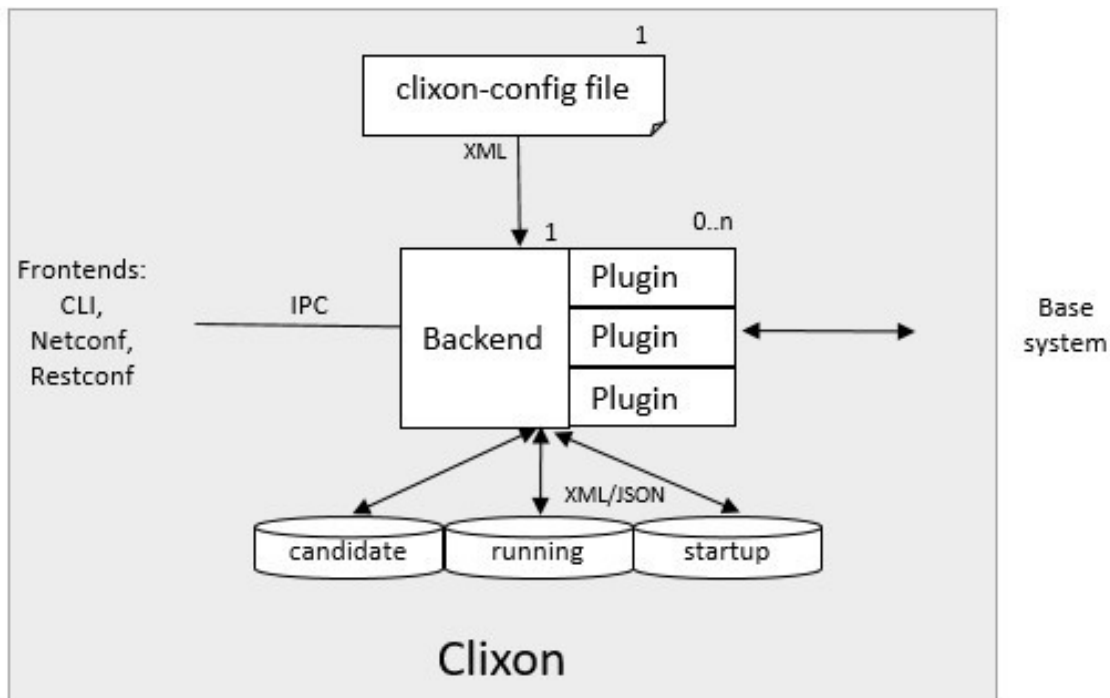

The backend daemon is the central component in the Clixon architecture. It consists of a main module and a number of dynamically loaded plugins. The backend has four APIs:

configuration

An XML file read at startup, possibly amended with *-o* options.

Internal interface / IPC

A NETCONF socket to frontend clients. This is by default a UNIX domain socket but can also be an IPv4 or IPv6 TCP socket but with limited functionality.

Datstores

XML (or JSON) files storing configuration. The three main datstores are *candidate*, *running* and *startup*. A user edits the candidate datstore, commits the changes to running which triggers callbacks in plugins.

Application

Backend plugins configure the base system with application-specific APIs. These APIs depend on how the underlying system is configured, examples include configuration files or a socket.

Note that a user typically does not access the datstores directly, it is possible to read, but write operations should not be done, since the backend daemon in most cases uses a datstore cache.

7.1 7.1 Command-line options

The backend have the following command-line options:

-h	Help
-D <level>	Debug level
-f <file>	Clixon config file
-E <dir>	Extra configuration directory
-l <option>	Log on (s)yslog, std(e)rr, std(o)ut, (n)one or (f)ile. Syslog is default. If foreground, then syslog and stderr is default.
-C <format>	Dump configuration options on stdout after loading. Format is one of xml json text
-d <dir>	Specify backend plugin directory
-p <dir>	Add Yang directory path (see CLICON_YANG_DIR)
-b <dir>	Specify datastore directory
-F	Run in foreground, do not run as daemon
-z	Kill other config daemon and exit
-a <family>	Internal backend socket family: UNIX IPv4 IPv6
-u <path addr>	Internal socket domain path or IP addr (see -a)
-P <file>	Process ID filename
-l	Run once and then quit (do not wait for events)
-s <mode>	Specify backend startup mode: none startup running init)
-c <file>	Load extra XML configuration file, but do not commit.
-q	Quit startup directly after upgrading and print result on stdout
-U <user>	Run backend daemon as this user AND drop privileges permanently
-g <group>	Client membership required to this group (default: clixon)
-y <file>	Load yang spec file (override yang main module)
-A	Do not clear autocli cache on start
-o <option=value>	Give configuration option overriding config file (see clixon-config.yang)

7.1.1 7.1.1 Logging and debugging

In case of debugging, the backend can be run in the foreground and with debug flags:

```
clixon_backend -FD 1
```

Note that debug levels can be combined as described in Section *debugging*.

Logging is by default on syslog. Alternatively, logging can be made on a file using the *-l* option:

```
clixon_backend -lf<file>
```

When run in foreground, logging is by default done on both syslog and stderr.

In a debugging mode, it can be useful to run in *once-only* mode, where the backend quits directly after starting up, instead of waiting for events:

```
clixon_backend -F1D 1
```

It may be useful to see all config options after load, taking into account default values, config-dirs and option overriding. This is normally dumped in debug level 1.

But you can also make an explicit dump of all config options on stdout using the *-C* option:

```
clixon_backend -1C xml
```

7.2 7.2 Startup

The backend can perform startup in four different modes. The difference is how the running state is handled, i.e., what state the system is in when you start the daemon and how loading the configuration affects it:

none

Do not touch running state. Typically after crash when running state and db are synched.

init

Initialize running state. Start with a completely clean running state.

running

Commit running db configuration into running state. Typically after reboot if a persistent running db exists.

startup

Commit startup configuration into running state. After reboot when no persistent running db exists.

The following config option is related to startup:

CLICON_STARTUP_MODE

Which method to start the backend

Use the *-s* option to select startup mode, example:

```
clixon_backend -s running
```

You may also add a default method in the configuration file:

```
<clixon-config xmlns="http://clixon.org/config">
  ...
  <CLICON_STARTUP_MODE>init</CLICON_STARTUP_MODE
</clixon-config>
```

When loading the startup/tmp configuration, the following actions are performed by the system:

- Check syntax errors,
- Upgrade callbacks.
- Validation of the XML against the current Yang models
- If errors are detected, enter *failsafe* mode.

7.3 7.3 IPC Socket

Frontends:		+-----+
CLI,	IPC	backend
netconf	<--->	daemon
restconf		
		+-----+

The Clixon backend creates a socket that the frontend clients can connect to. Communication is made over this IPC socket using internal Netconf. The following config options are related to the internal socket:

CLICON SOCK FAMILY

Address family for communicating with `clixon_backend`. One of: UNIX, IPv4, or IPv6. Can also be set with `-a` command-line option. Default is UNIX which denotes a UNIX domain socket.

CLICON SOCK

If the address family of the socket is `AF_UNIX`: Unix socket for communicating with `clixon_backend`. If the family is `AF_INET` it denotes the IPv4 address;

CLICON SOCK PORT

Inet socket port for communicating with `clixon_backend` (only IPv4|IPv6). Default is port 4535.

CLICON SOCK GROUP

Group membership to access `clixon_backend` UNIX socket. Default is `clixon`. This is not available for IP sockets.

7.4 7.4 Backend files

The following config options control files related to the backend:

CLICON_BACKEND_DIR

Location of backend `.so` plugins. Load all `.so` plugins in this dir as backend plugins in alphabetical order

CLICON_BACKEND_REGEX

Regex of matching backend plugins in `CLICON_BACKEND_DIR`. default: `*.so`

CLICON_BACKEND_PIDFILE

Process-id file of backend daemon

7.5 7.5 Backend plugins

This section describes backend-specific plugins, see *Plugin section* for a general description of plugins.

7.5.1 7.5.1 Clixon_plugin_init

Apart from the generic plugin callbacks (`init`, `start`, etc), the following callbacks are specific to the backend:

pre_daemon

Called just before server daemonizes(forks). Not called if in foreground.

daemon

Called after the server has daemonized and before privileges are dropped.

statedata

Provide state data XML from a plugin

reset

Reset system status

upgrade

General-purpose upgrade called once when loading the startup datastore

trans_{begin,validate,complete,commit,commit_done,revert,end,abort}

Transaction callbacks are invoked for two reasons: validation requests or commits. These callbacks are further described in *transactions* section.

7.5.2 7.5.2 Registered callbacks

The callback also supports three forms of registered callbacks:

- `rpc_callback_register()` - for user-defined RPC callbacks, see *Plugin section*.
- `action_callback_register()` - for user-defined Action callbacks.
- `upgrade_callback_register()` - for upgrading, see *Upgrade section*.
- `clixon_pagination_cb_register()` - for pagination, as described in *Pagination section*.

7.6 7.6 Writing a state callback

The `ca_statedata` callback is used retrieving non-configuration (state) data. This is typically done for NETCONF <get> or RESTCONF GET requests.

A plugin can only register a single callback, but can be used for multiple state data trees.

The `statedata` API is pretty basic, it is not called for a specific XPath, it is called once per plugin. A plugin should submit all its state data in one call.

7.6.1 7.6.1 Arguments

The `statedata` callback is called with the following arguments:

- `h`: Clixon handle
- `xpath`: Part of state requested
- `nsc`: Namespace context of XPath
- `xconfig`: XML tree

A plugin should add state data to `xconfig` XML tree for state data matching `xpath`.

7.6.2 7.6.2 Xconfig

The callback is called with an `xconfig` parameter, which is a top-level XML tree where you should add state-data matching `xpath` on the form:

```
<config/>
```

The plugin is expected to add state data to this tree, for example:

```

<config
  <store xmlns="urn:example:std">
    <keys>
      <key>
        <name>a</name>
      </key>
    </keys>
  </store>
</config>

```

7.6.3 7.6.3 XPath

The callback is also called with an `xpath` and a corresponding `nsc` namespace context. The callback matches the XPath with its system data, and returns the data if the XPath matches.

The XPath is given as part of the original request, e.g., the `<filter>` element.

If the XPath is `/` the whole system state is requested, but if the XPath is more specific, such as `/a`, only system state for the `<a>` top-level tree is expected.

The XPath reflects the original filtering in the the NETCONF `select` tag, or RESTCONF URI. Without such filtering, the callback is called with XPath `/` to match all data.

Since it is difficult to match XPaths in the general case, it is not strictly necessary to match the XPath. If system state is given which does not match the XPath, it is filtered at a later stage. However, filtering on XPaths give better performance.

7.6.4 7.6.4 Example

In the following example, the state data is hardcoded, whereas a real example would extract this information from the system:

```

int
example_statedata(clixon_handle h,
                  cvec          *nsc,
                  char          *xpath,
                  cxobj         *xconfig)
{
  if (clixon_xml_parse_string("<store xmlns=\"urn:example:std\">
                              <keys>
                                <key>
                                  <name>a</name>
                                </key>
                              </keys>
                              </store>",
                              YB_NONE, 0, &xconfig, 0) < 0)
    err;
  ...
}
static clixon_plugin_api api = {
  ...
  .ca_statedata=example_statedata,

```

Note that the constructed XML must be a valid with respect to YANG from the top-level all the way down to the system-only data, which includes having valid list keys.

Note also that no match with XPath is done. For example, an XPath of `/system` would not match the `<store>` top-level.

7.6.5 7.6.5 Errors

If the callback returns an invalid XML, an *operation-failed* NETCONF error is returned. Something like:

```
<rpc-reply xmlns="urn:ietf:params:xml:ns:netconf:base:1.0">
  <rpc-error>
    <error-type>application</error-type>
    <error-tag>operation-failed</error-tag>
    <error-info>
      <bad-element>store</bad-element>
    </error-info>
    <error-severity>error</error-severity>
    <error-message>Failed to find YANG spec of XML node: store with parent: config in
↳ namespace: urn:example:std. Internal error, state callback returned invalid XML from
↳ plugin: example_statedata</error-message>
  </rpc-error>
</rpc-reply>
```

7.7 7.7 Transactions

Clixon follows NETCONF in its validate and commit semantics. Using the CLI or another frontend, you edit the *candidate* configuration, which is first *validated* for consistency and then *committed* to the *running* configuration.

A clixon developer writes commit functions to incrementally update a system state based on configuration changes. Writing transaction callbacks is a core function of the clixon system.

The NETCONF validation and commit operation is implemented in clixon by a transaction mechanism, which ensures that user-written plugin callbacks are invoked atomically and revert on error.

Note: Clixon currently runs in a single thread and all transactions run from *begin*, to *end* without interruption. However, it is strongly recommended that the callbacks be thread-safe for future compatibility.

Warning: Clixon can only guarantee a consistent system state if you follow the guidelines below. Behavior that is not documented here is not guaranteed and subject to change without notice.

The phases of a transaction are:

begin

The *begin* callback indicates that a transaction is starting, but that the system level validation has not begun yet. Not much has happened at this point, and you should not rely on the transaction data or the XML ADD/DEL/CHANGE flags.

The intent of this callback is to notify the plugin that a transaction is beginning, and that it should allocate any resources necessary to handle the coming transaction.

validate

The validate callback is triggered by a client requesting a validation of the current change set. Before this callback, clixon has completed the system level YANG validation. All transaction data is valid at this point (including XML flags). In this callback, the plugin further validates the transaction data and returns a success/failure indication. It must not change the state of the system in any way. Successful completion should guarantee that the commit will be without error. See the commit information below on why it is important to try. If a failure status is returned to clixon then the transaction is cancelled, and the transaction abort callback will be called from clixon.

You should place as much of the validation in the YANG model specification as possible. This does two things; it allows the user of the YANG model to understand the constraints clearly, and it is more efficient when the YANG validation catches problems before a transaction cycle happens.

complete

This callback is used to indicate to the plugin that the validation was successful and indicates that the commit is coming next. The transaction data will be valid when this callback is called. The complete callback must not change the state of the system.

The usefulness of this callback is debatable, and it is possible that this callback will be removed in a future version.

commit

This callback is called when the client requests a commit. The transaction data is valid, and both the system and plugin validations of the transaction data has completed without error.

The callback should perform the actions required to change the system state as indicated by the transaction target database.

Ideally all possible errors should be detected in the validate callback, but this clearly is a dream. A commit failure is a major event and leaves the system in an inconsistent state. In the event of an error, the callback must return an error status. Clixon will initiate its error processing to roll back the system to its state prior to the beginning of the transaction.

commit_done

Transaction when commit done. After this, the source db is copied to target and default values removed.

end

The end callback is called when a transaction has successfully completed.

You should not depend upon transaction data being valid at this point and no changes to the system state may occur (changes at this point prevent the possibility of error handling).

Any resources allocated in the begin callback should be released at this point. When the callback returns, the transaction is complete.

commit_failed

This callback is called in case of commit callback failure, run once and will be followed by a revert callback. The code placed here is capable for incremental rollback of the “prints” that were made by failed commit callback.

revert

When the revert callback is called the plugin must revert the system to the state prior (atomicity) to the beginning of the transaction. The transaction data is valid and is the same as in the commit callback. The code in the revert callback must assure that the system state matches the source database before returning.

A revert callback will be followed by an abort callback.

abort

If a validate or commit operation fails, the terminal action is to call the abort callback rather than the end callback. The common purpose of this callback is to release any resources allocated in the begin callback.

If an abort callback occurs after a commit, then the revert callback will be called prior to the abort. The plugin developer may do the actual reversion of the commit in the revert or abort callback, or split the duties as desired,

but upon completion of the abort callback, it must be guaranteed that the system state will be as before the begin callback.

7.7.1 7.7.1 Transaction Examples

In a system with two plugins, for example, a transaction sequence looks like the following:

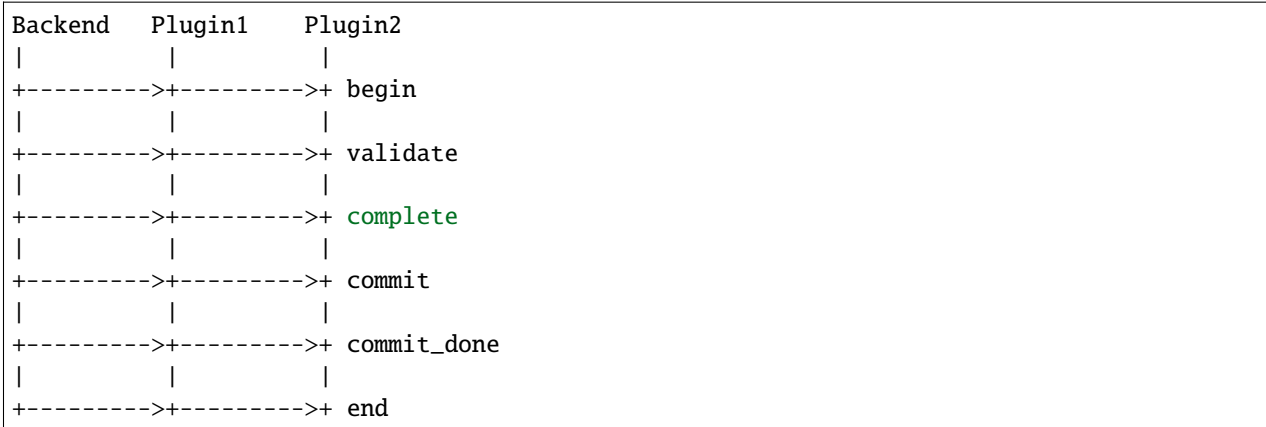

If an error occurs in the commit call of plugin2, for example, the transaction is aborted and the commit reverted:

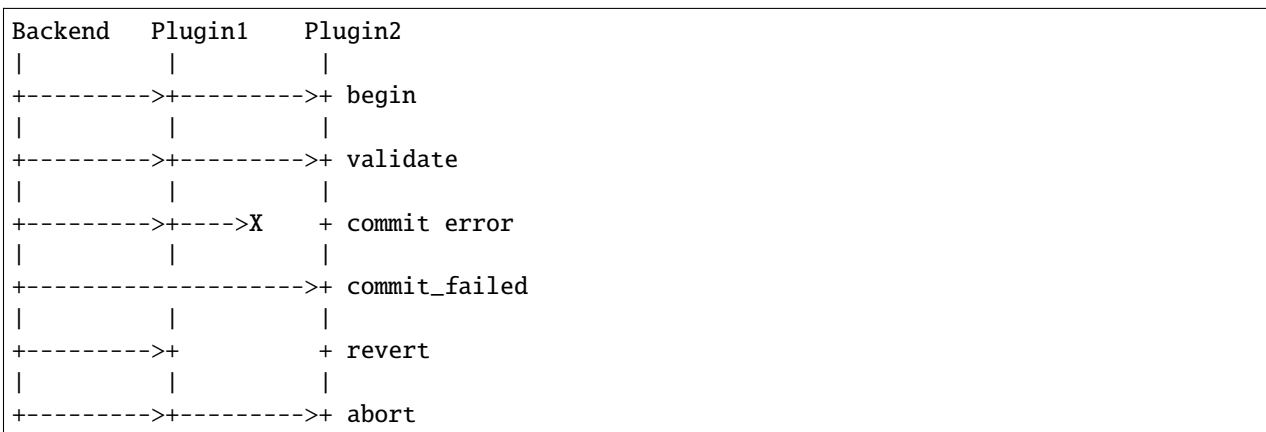

7.7.2 7.7.2 Callbacks

In the the context of a callback, there are two XML trees:

src

The original XML tree, such as “running”

target

The new XML tree, such as “candidate”

There are three vectors pointing into the XML trees:

delete

The delete vector consists of XML nodes in “src” that are removed in “target”

add

The add vector consists of nodes that exists in “target” and do not exist in “src”

change

The change vector consists of nodes that exists in both “src” and “target” but are different

All transaction callbacks are called with a transaction-data argument (td). The transaction data describes a system transition from a src to target state. The struct contains source and target XML tree (e.g. candidate/running) in the form of XML tree vectors (dvec, avec, cvec) and associated lengths. These contain the difference between src and target XML, ie “what has changed”. It is up to the validate callbacks to ensure that these changes are OK. It is up to the commit callbacks to enforce these changes in the configuration of the system.

The “td” parameter can be accessed with the following functions:

```
uint64_t transaction_id(transaction_data td)
    Get the unique transaction-id

void *transaction_arg(transaction_data td)
    Get plugin/application specific callback argument

int transaction_arg_set(transaction_data td, void *arg)
    Set callback argument

cxobj *transaction_src(transaction_data td)
    Get source database xml tree

cxobj *transaction_target(transaction_data td)
    Get target database xml tree

cxobj **transaction_dvec(transaction_data td)
    Get vector of xml nodes that are deleted src->target

size_t transaction_dlen(transaction_data td)
    Get length of delete xml vector

cxobj **transaction_avec(transaction_data td)
    Get vector of xml nodes that are added src->target

size_t transaction_alen(transaction_data td)
    Get length of add xml vector

cxobj **transaction_scvec(transaction_data td)
    Get vector of xml nodes that changed

cxobj **transaction_tcvec(transaction_data td)
    Get vector of xml nodes that changed

size_t transaction_clen(transaction_data td)
    Get length of changed xml vector
```

Example:

```
#define NAME "clixon-plug-example"
int commit_done(clicon_handle    h,
                transaction_data  td)
{
    int          retval = -1;
    const int    MAX_SIZE = 100;
    size_t       count = 0;
    size_t       change_count
    cxobj        **added_data = NULL;
    char          *parents[MAX_SIZE]; // just example
    cxobj        *added = NULL;
    cxobj        *parent_node = NULL;
```

(continues on next page)

(continued from previous page)

```

cbuf      *source_buffer = NULL;

clicon_log(LOG_INFO, "[%s]: commit_done start", NAME);
clicon_log(LOG_INFO, "[%s]: transaction_clen = %zu", NAME, transaction_clen(td));
clicon_log(LOG_INFO, "[%s]: transaction_alen = %zu", NAME, transaction_alen(td));
clicon_log(LOG_INFO, "[%s]: transaction_dlen = %zu", NAME, transaction_dlen(td));

added_data = transaction_avec(td); // diff
change_count = transaction_alen(td); // count diff

if (change_count == 0)
    goto done;
for (size_t i = 0; i < change_count; ++i) {
    added = added_data[i];
    parent_node = xml_parent(added);
    parents[count] = xml_name(parent_node);
    count++;
    while (parent_node) {
        parent_node = xml_parent(parent_node);
        if (parent_node) {
            parents[count] = xml_name(parent_node);
            count++;
            if (count >= MAX_SIZE)
                goto done;
        }
    }
    clicon_log(LOG_INFO, "[%s]: parent node OK", NAME);
    source_buffer = cbuf_new();
    if (source_buffer == NULL)
        goto done;
    else {
        if (clicon_xml2cbuf(source_buffer, added, 0, 0, (char*)"", -1, 0) != -1)
            goto done;
    }
}
clicon_log(LOG_INFO, "[%s]: commit_done done", NAME);
retval = 0;
done:
return retval;
}

```

Flags

A programmer can also use XML flags that are set in “src” and “target” XML trees to identify what has changed. The following flags are used to make the trees:

XML_FLAG_DEL

All deleted XML nodes in “src” and all its descendants

XML_FLAG_ADD

All added XML nodes in “target” and all its descendants

XML_FLAG_CHANGE

All changed XML nodes in both “src” and “target” and all its descendants. Also all ancestors of all added, deleted and changed nodes.

For example, assume the tree (A B) is replaced with (B C), then the two trees are marked with the following flags:

	src	target
	o CHANGE	o CHANGE
	o CHANGE	o CHANGE
	/	\
DELETE	A B	B C ADD

You can use functions, such as `xpath_vec_flag()` to query for changed nodes:

```
if (xpath_vec_flag(xcur, nsc, "//symbol/foo", XML_FLAG_ADD, &vec, &veclen) < 0)
    err;
for (i=0; i<veclen; i++){
    xn = vec[i];
    ...
}
```

7.8 7.8 Privileges

The backend process itself does not really require any specific access, but it may be an important topic for an application using clixon when the plugins are designed. A plugin may need to access privileged system resources (such as configure files).

The backend itself is usually started as root: `sudo clixon_backend -s init`, which means that the plugins also run as root (being part of the same process).

The backend can also be started as a non-root user. However, you may need to set some config options to allow user write access, for example as follows(there may be others):

```
<CLICON_SOCKET>/tmp/example.sock</CLICON_SOCKET>
<CLICON_BACKEND_PIDFILE>/tmp/mytest/example.pid</CLICON_BACKEND_PIDFILE>
<CLICON_XMLDB_DIR>/tmp/mytest</CLICON_XMLDB_DIR>
```

7.8.1 7.8.1 Dropping privileges

You may want to start the backend as root and then drop privileges to a non-root user which is a common technique to limit exposure of exploits.

This can be done either by command line-options: `sudo clixon_backend -s init -U clixon` or (more generally) using configure options:

```
<CLICON_BACKEND_USER>clixon</CLICON_BACKEND_USER>
<CLICON_BACKEND_PRIVILEGES>drop_perm</CLICON_BACKEND_PRIVILEGES>
```

This will initialize resources as root and then *permanently* drop uid:s to the unprivileged user (*clixon* in the example above). It will also change ownership of several files to the user, including datastores and the clixon socket (if the socket is unix domain).

Note that the unprivileged user must exist on the system, see *Install section*.

7.8.2 7.8.2 Drop privileges temporary

If you drop privileges permanently, you need to access all privileged resources initially before the drop. For a plugin designer, this means that you need to access privileges system resources in the *plugin_init* or *plugin_start* callbacks. The transaction callbacks, for example, will be run in unprivileged mode.

An alternative is to drop privileges temporary and then be able to raise privileges when needed:

```
<CLICON_BACKEND_USER>clixon</CLICON_BACKEND_USER>  
<CLICON_BACKEND_PRIVILEGES>drop_temp</CLICON_BACKEND_PRIVILEGES>
```

In this mode, a plugin callback (eg commit), can temporarily raise the privileges when accessing system resources, and the lower them when done.

An example C-code for raising privileges in a plugin is as follows:

```
uid_t euid = geteuid();  
restore_priv();  
... make high privilege stuff...  
drop_priv_temp(euid);
```

8 DATASTORE

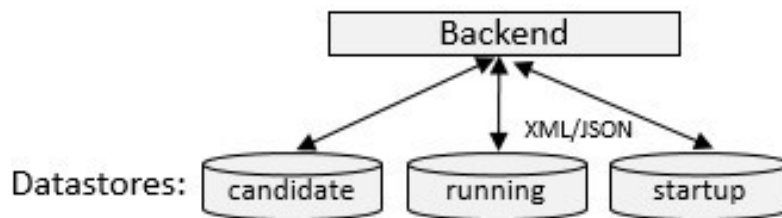

Clixon configuration datastores follow the Netconf model (from [RFC 6241](#)):

Candidate

A configuration datastore that can be manipulated without impacting the device's current configuration and that can be committed to the running configuration datastore.

Running

A configuration datastore holding the complete configuration currently active on the device.

Startup

The configuration datastore holding the configuration loaded by the device when it boots. Only present on devices that separate the startup configuration datastore from the running configuration datastore.

There are also other datastores, Clixon is not limited to the three datastores above. For example:

Tmp

The tmp datastore appears in several cases as an intermediate datastore.

Rollback

If the confirmed-commit feature is enabled, the rollback datastore holds the running datastore as it existed before the confirm commit. If a cancel or timeout occurs, the rollback datastore is used to revert to.

8.1 8.1 Datastore files

Clixon datastores are stored in regular files, by default one file per datastore.

8.1.1 8.1.1 Options

Dastore files are controlled by the following options:

CLICON_XMLDB_DIR

Mandatory directory where datastores are placed.

CLICON_XMLDB_MULTI

Split configure datastore into multiple sub files. Default is single file. Only applicable for YANG schema mounts

Dastores files are only accessible by the user that starts the backend. Typically this is *root*, but if the backend is started as a non-privileged user, or if privileges are dropped (see *Backend section*) this may be another user, such as in the following example where *clicon* is used:

```
sh> ls -l /usr/local/var/example
-rwx----- 1 clicon clicon  0 sep 15 17:02 candidate_db
-rwx----- 1 clicon clicon  0 sep 15 17:02 running_db
-rwx----- 1 clicon clicon  0 sep 14 18:12 startup_db
```

8.1.2 8.1.2 Split datastores

By default, a datastore is a single file. However, it is possible to split the store into multiple files in a *db.d/* directory. For example:

```
> ls -l /usr/local/var/multi/running.d/
0.xml
35819a66.xml
762894da.xml
...
```

where:

- *0.xml* is a top-level datastore
- *35819a66.xml* is a sub-store linked from *0.xml*

There are some limitations to split datastores:

- XML is the only format supported by split datastores.
- One-level of splits are allowed, that is, a sub-store may not link to another sub-store

Backward-compatibility is ensured by reading *<db>_db* if *<db>.d/0.xml* is not present at startup.

The sub filenames are SHA1 digests of the XPath to the XML node where the split is made.

A typical example of splitting a datastore is in combination with RFC 8528 YANG Schema mounts.

Mechanism

The YANG `cl:xmlldb-split` extension and the `cl:link` attribute is used to define how datastores are split as the following example illustrates.

Assume a YANG specification with nodes *a* and *b*:

```

container a {
  cl:xmlldb-split {
    description "Multi-XMLDB: split datastore here";
  }
  container b {
    description "Will be in separate file";
  }
}

```

If the YANG above is instantiated to, for example, `<a>foo`, this will result in the following two datastores:

```

0.xml:
<config>
  <a xmlns:cl="http://clixon.org/lib" cl:link="35819a66.xml"/>
</config>

35819a66.xml:
<config>
  <b>foo</b>
</config>

```

8.2 8.2 File formats

The format of the datastores can be changed using the following options:

CLICON_XMLDB_FORMAT

Datastore format. *xml* is the primary alternative. *json* is also available

CLICON_XMLDB_PRETTY

XMLDB datastore pretty print. The default value is *true*, which inserts spaces and line-feeds making the XML/JSON human readable. If false, the XML/JSON is more compact.

Limitations:

- Format settings apply to all datastores
- *xml* and *json* are allowed for single datastores
- *xml* is allowed for split datastores

8.2.1 8.2.1 XML format

By default, datastore files use pretty-printed XML with `<config>` as the top-level wrapper element. All data model nodes carry their YANG namespace declared with `xmlns`. The following is an example of a valid XML datastore for a YANG list parameter defined in module `example` with namespace `urn:example:clixon`:

```
<config>
  <table xmlns="urn:example:clixon">
    <parameter>
      <name>a</name>
      <value>42</value>
    </parameter>
    <parameter>
      <name>b</name>
      <value>99</value>
    </parameter>
  </table>
</config>
```

8.2.2 8.2.2 JSON format

When `CLICON_XMLDB_FORMAT` is set to `json`, datastore files follow [RFC 7951](#) (JSON Encoding of YANG Data). The top-level wrapper key is `"config"`, mirroring the XML `<config>` element. All data model nodes are encoded with their YANG module name as a namespace prefix, i.e. `"<module>:<node>"`.

The following is an example of a valid JSON datastore for the same parameter list:

```
{
  "config": {
    "example:table": {
      "example:parameter": [
        {
          "example:name": "a",
          "example:value": "42"
        },
        {
          "example:name": "b",
          "example:value": "99"
        }
      ]
    }
  }
}
```

Note: The module-name prefix on every node is required by RFC 7951 and must match the YANG module that defines the node, not any imported module. Omitting the prefix causes a parse error.

8.3 8.3 Caching

Clixon stores datastore content in an in-memory write-through cache managed by the Clixon backend. As soon as data is modified in-mem, a write is made to file. Reads from file is made only on startup, or more precisely, if the cache is empty. Modifications by an external part of the file is only read by the backend on startup.

8.3.1 8.3.1 Per-datastore cache policy

The default write-through behaviour (keep data both in memory and on disk) is appropriate for most datastores. However, different datastores have different persistence requirements:

- **running** — must survive a backend restart; keep both in memory and on file.
- **candidate** — a temporary working copy; in-memory only is safe and avoids unnecessary disk I/O.
- **startup** — read at boot and written when committed; file-only avoids holding a duplicate copy in RAM.

The CLICON_XMLDB_CACHE_STATUS configuration option is a list that lets you override the default policy per datastore.

Cache modes

Three cache modes are available:

file-inmem (*default*)

Write-through cache. Data is kept in memory and written to disk on every modification. Reads come from memory after the initial load from file at startup. This is the default for all datastores unless overridden.

inmem

In-memory only. Data is never written to disk. The datastore is volatile and its contents are lost when the backend exits. Useful for the candidate datastore when persistence is not required, or for any ephemeral datastore.

file

File only (no persistent in-memory cache). The datastore file is read on every access and the in-memory copy is discarded after each read. This is appropriate for the startup datastore where the file is accessed infrequently and memory savings matter.

Configuration

CLICON_XMLDB_CACHE_STATUS is a list keyed on the datastore name. Each entry has a name (e.g. candidate, running, startup) and a status value (file-inmem, inmem, or file).

A typical configuration that makes the candidate datastore volatile and keeps the startup datastore file-only:

```
<CLICON_XMLDB_CACHE_STATUS>
  <name>candidate</name>
  <status>inmem</status>
</CLICON_XMLDB_CACHE_STATUS>
<CLICON_XMLDB_CACHE_STATUS>
  <name>startup</name>
  <status>file</status>
</CLICON_XMLDB_CACHE_STATUS>
```

Datastores not listed use the default file-inmem policy.

Note: An `inmem` candidate is lost when the backend restarts. After restart the candidate is re-initialised from the running datastore, which is normal NETCONF behaviour.

8.4 8.4 Candidate

The candidate datastore can be manipulated without impacting the current, running configuration of a device, and can be committed to the running datastore.

8.4.1 8.4.1 Options

CLICON_AUTOLOCK

Get exclusive lock automatically by `edit-config` and `copy-config` and released by `discard` and `commit`.

8.4.2 8.4.2 Shared candidate

By default and as defined in [RFC 6241: NETCONF Configuration Protocol](#), the candidate datastore is *shared*, meaning that other clients can modify the candidate configuration simultaneously.

8.4.3 8.4.3 Exclusive access

An exclusive lock on the shared candidate prohibits other clients to make changes while the client is editing.

There are two ways to obtain an exclusive lock, either explicitly or implicitly:

- An *explicit* lock is made the NETCONF `lock` operation or by corresponding CLI operation.
- *Implicit* locks are enabled by setting `<CLICON_AUTOLOCK>true</CLICON_AUTOLOCK>` in the configuration file.

An implicit lock is obtained by `edit-config` and `copy-config` and released by `discard` and `commit`.

Locking is not available in RESTCONF.

8.4.4 8.4.4 Private candidate

Clixon implements private candidate as defined in [NETCONF and RESTCONF Private Candidate Datastores](#).

To enable private candidate the `CLICON_XMLDB_PRIVATE_CANDIDATE` option must be set to true and the feature `ietf-netconf-private-candidate:private-candidate` must be added to the Clixon configuration.:

```
<CLICON_FEATURE>ietf-netconf-private-candidate:private-candidate</CLICON_FEATURE>
<CLICON_XMLDB_PRIVATE_CANDIDATE>true</CLICON_XMLDB_PRIVATE_CANDIDATE>
```

All NETCONF clients must send the capability: `urn:ietf:params:netconf:capability:private-candidate:1.0` when connecting, otherwise the session will be terminated by Clixon.

When a conflict is detected by the `<update>` operation or implicitly during `commit`, the error message contains the type of conflict and the xpath to the object of the first conflict encountered.

```
<rpc-error>
  <error-type>application</error-type>
  <error-tag>operation-failed</error-tag>
  <error-severity>error</error-severity>
  <error-message>Conflict occured: Cannot change node value, node is removed: xpath0: /
  ↪ interfaces/interface[name="intf_one"]</error-message>
</rpc-error>
```

A conflict can be handled by discarding all changes made to the private candidate using the `<discard-changes>` command and then retrieving the latest configuration from the running configuration to the private candidate using `<update>`.

```
<discard-changes/>
<update xmlns="urn:ietf:params:xml:ns:netconf:private-candidate:1.0"/>
```

On a successful `<commit>`, the running configuration is updated with the changes from the private candidate, after which the private candidate is deleted. A new private candidate is created from the running configuration on the first call of any operation involving the candidate, e.g. `<edit-config>`.

CLI example

The following commands may be specified to manage private candidates using the cli

```
show("Show configuration") {
  candidate("Show private candidate configuration"), cli_show_auto_mode("candidate",
  ↪ "text", true, false);
  running("Show running configuration"), cli_show_auto_mode("running", "text", true,
  ↪ false);
}
compare("Compare private candidate and running databases"), compare_dbs("running",
  ↪ "candidate", "text");
set("Edit private candidate") @datamodel, cli_auto_set();
discard("Discard changes in private candidate"), discard_changes();
update("Update private candidate from running if no conflicts"), cli_update();
commit("Commit the changes if no conflicts"), cli_commit();
```

Scenario using these cli commands to handle a conflict

```
> set interfaces interface intf_one description "Link to Gothenburg"
> compare
  interface intf_one {
-   description "Link to London";
+   description "Link to Gothenburg";
  }
```

some other session updates the same interface

```
> commit
Conflict occured: Cannot change node value, it is already changed: xpath0: /
↪ interfaces/interface[name="intf_one"]/description value0: Link to London value1: Link
↪ to Gothenburg
> discard
> update
> set interfaces interface intf_one description "Link to Gothenburg"
```

(continues on next page)

(continued from previous page)

```

> compare
  interface intf_one {
-   description "Link to Stockholm";
+   description "Link to Gothenburg";
  }
> commit
> show running
ietf-interfaces:interfaces {
  interface intf_one {
    description "Link to Gothenburg";
  }
}

```

8.5 8.5 Module library support

Clixon can store Yang module-state information according to [RFC 8525: YANG library](#) in the datastores. With module state, you know which Yang version the XML belongs to, which is useful when upgrading, see *upgrade*.

8.5.1 8.5.1 Options

CLICON_XMLDB_MODSTATE

Tag datastores with RFC 8525 YANG Module Library info

8.5.2 8.5.2 Operation

To enable yang module-state in the datastores add the following entry in the Clixon configuration:

```

<CLICON YANG LIBRARY>true</CLICON YANG LIBRARY> # (default true)
<CLICON_XMLDB_MODSTATE>true</CLICON_XMLDB_MODSTATE>

```

If the datastore does not contain module-state, general-purpose upgrade is the only upgrade mechanism available.

A backend with CLICON_XMLDB_MODSTATE disabled will silently ignore module state.

Example of a (simplified) datastore with Yang module-state:

```

<config>
  <a1 xmlns="urn:example:a">some text</a1>
  <!-- Here goes regular config -->
  <yang-library xmlns="urn:ietf:params:xml:ns:yang:ietf-yang-library">
    <content-id>42</content-id>
    <module-set>
      <name>default</name>
      <module>
        <name>A</name>
        <revision>2019-01-01</revision>
        <namespace>urn:example:a</namespace>
      </module>
    </module-set>
  </yang-library>

```

(continues on next page)

(continued from previous page)

```
</yang-library>
</config>
```

Note that the module-state is not available to the user, the backend datastore handler strips the module-state info. It is only shown in the datastore itself.

8.6 8.6 System-only config

System-only config is a mechanism to disable storing of sensitive configuration data in the datastore. Instead, a user implements application callbacks to store the data in a *system state*, which could be something like a system configuration file (e.g., a password file), a system call, device config, etc.

System-only config is never stored in datastore files and is stored in memory only temporary while a candidate commit is taking place.

Note: System-only config is never stored in datastore files.

This guide follows the test and main example in the clixon repository. The code in this description is somewhat simplified, see the following files for full details: `test/test_datastore_system_only.sh` and the clixon main example `example/main/example_backend.c`.

8.6.1 8.6.1 Options

CLICON_XMLDB_SYSTEM_ONLY_CONFIG

Enable system-only-config, set to true

8.6.2 8.6.2 Restrictions

The following functionality is restricted with system-only config:

- Rollbacks
- Commit confirm

The reason saved configurations as rollbacks do not support system-only config is simply that system-only config is not stored in configuration files. Rollback of system-only needs to be solved by other means.

8.6.3 8.6.3 Source-of-truth

System-only config acts as source of truth in the sense that a user can modify the system directly, outside clixon. For example, modifying a password via the OS, or calling a system-call directly.

This is different from regular configured data, where NETCONF clients are the only configuration source. Any direct modification of configured data is ignored, and is overwritten at next commit.

Running

Example: Assume a system-only data A initially is set to: A=X. A `get-config running` retrieves X.

Then, set A=Y directly by the system (not via clixon), then `get-config running` retrieves Y.

Likewise, if A=Z via NETCONF and committed, then `get-config running` retrieves Z.

Candidate

A candidate which is not locked or modified behaves as running. That is, changed system-only config also appears in candidate.

However, as soon as candidate is modified or locked, the system-only config is not changed.

For example, assume a system-only config is initially set to A=X.

Assume then a NETCONF client performs `lock candidate` (or `edit-config`). Then, `get-config candidate` still retrieves X and there is no difference between running and candidate.

Then, A=Y is set directly by the system (not via clixon), then `get-config candidate` retrieves X but `get-config running` retrieves Y.

A `show compare` of candidate and running shows:

```
- A Y
+ A X
```

If now a NETCONF client performs `edit-config A=Z`. Then, `get-config candidate` retrieves Z and `get-config running` retrieves Y.

A `show compare` of candidate and running shows:

```
- A Y
+ A Z
```

And a `commit` sets running: A=Z.

Note that for RESTCONF or short edit/commit cycles, this is usually inconsequential.

8.6.4 8.6.4 Extensions

You identify and mark state-only YANG elements with the `system-only-config` extension. This is done either by:

1. Directly marking the element
2. Using `augment` to mark a standard YANG from a local YANG

The logic of the second approach is a standard YANG not under your control.

The example uses the second approach with a *clixon-standard* YANG as follows:

```
module clixon-standard{
  yang-version 1.1;
  namespace "urn:example:std";
  prefix std;
  grouping system-only-group {
    leaf system-only-data { // <----
      type string;
    }
  }
}
```

(continues on next page)

(continued from previous page)

```

    }
  }
  grouping store-grouping {
    container keys {
      list key {
        key "name";
        leaf name {
          type string;
        }
        uses system-only-group;
      }
    }
  }
  container store {
    uses store-grouping;
  }
}

```

The second local module augments the standard YANG by marking the `system-only-data` with the `system-only-config` extension:

```

module clixon-local{
  yang-version 1.1;
  namespace "urn:example:local";
  prefix local;
  import clixon-lib {
    prefix cl;
  }
  import clixon-standard {
    prefix std;
  }
  augment "/std:store/std:keys/std:key/std:system-only-data" {
    cl:system-only-config; // <----
  }
}

```

8.6.5 8.6.5 Commit callback

The next step is to commit the `system-only-config` data following the regular commit callback mechanism described in the *backend section*.

The only difference is that the `system-only config` data is then deleted and not stored in `running-db`.

8.6.6 8.6.6 System-only callback

The last step is to write a system-only callback to recreate system-only data on read. This is necessary in a NETCONF get-config request, for example.

The purpose is to merge the system-only data into the cached XML tree in-memory after reading the datastore.

The way to add system-only config data is similar to how to add state data with the `ca_statedata` callback, as described in the *backend section*.

In this example, the system-only config data is hardcoded, whereas a real example would extract this information from the system.

Note that the constructed XML must be a valid with respect to YANG from the top-level all the way down to the system-only data, which includes having valid list keys:

```
int
main_system_only_callback(clixon_handle h,
                          cvec          *nsc,
                          char          *xpath,
                          cxobj         *xconfig)
{
    if (clixon_xml_parse_string("<store xmlns=\"urn:example:std\">
                                <keys>
                                  <key>
                                    <name>a</name>
                                    <system-only-data>mydata</system-only-data>
                                  </key>
                                </keys>
                                </store>",
                                YB_NONE, 0, &xconfig, 0) < 0)
        err;
    ...
}
static clixon_plugin_api api = {
    ...
    .ca_system_only=main_system_only_callback,
```

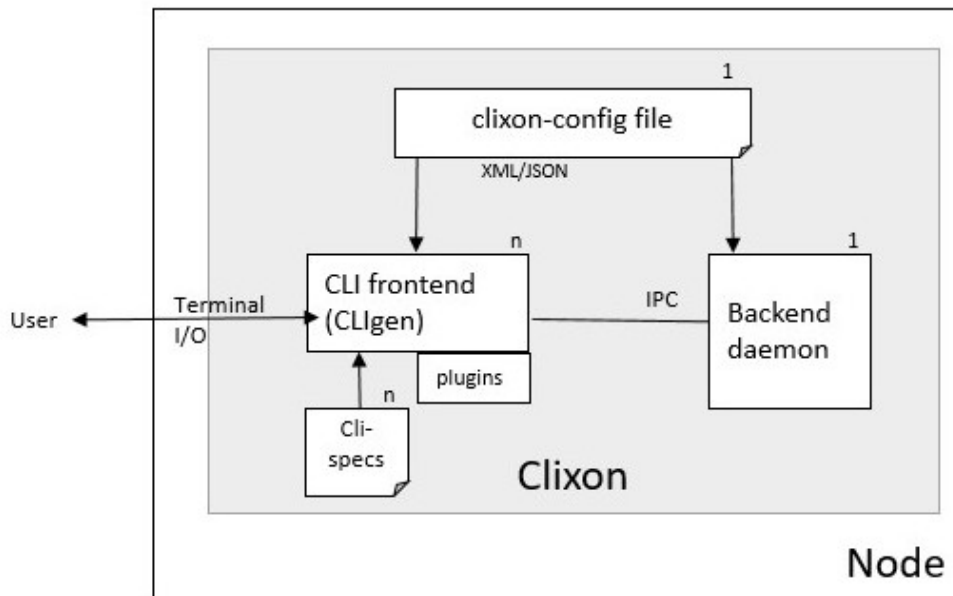

9.1 9.1 Overview

The Clixon CLI provides an interactive command-line interface to a user. Each usage instantiates a new process which communicates via NETCONF with the backend daemon over an IPC socket.

The Clixon CLI uses **CLIGen**, an interactive interpreter of commands. Syntax is given as *cli-specifications* which specify callbacks defined in plugins.

For details on CLIGen syntax and behavior, please consult the [CLIGen tutorial](#).

Clixon comes with a generated CLI, the *autocli*, where all configuration-related syntax is generated from YANG.

You can also create a completely manually-made CLI.

The CLI depends on the following:

- *Clixon-config*: The Clixon config-file contains initial CLI configuration, such as where to find cli-specs, plugins and autocli configuration.
- *Cli-specs*: CLI specification files written in **CLIGen** syntax.
- *Plugins*: Dynamic loadable plugin files loaded at startup. Callbacks from cli-spec files are resolved and need to exist as symbols either in the Clixon libs or in the plugin file.

The following example from the `main example`. First, a cli-spec file containing two commands:

```
set("Set configuration symbol") @datamodel, cli_auto_set();
show("Show a particular state of the system") configuration("Show configuration"), cli_
↳show_config("candidate", "default", "/");
example("Callback example") <var:int32>("any number"), mycallback("myarg");
```

In the CLI, these generate CLI commands such as:

```
set interfaces interface eth9
show config
example 23
```

The effect of typing the commands above is calling callbacks, either library functions in Clixon `libs(cli_show_config())`, or application-defined in a `plugin(mycallback())`

In this way, a designer writes cli command specifications which invokes C-callbacks. If there are no appropriate callbacks the designer must write a new callback function.

9.1.1 9.1.1 Example usage

The following example shows an auto-cli session from the `main example` how to add an interface in candidate, validate and commit it to running, then look at it as xml and cli and finally delete it:

```
clixon_cli -f /usr/local/etc/clixon/example.xml
user@host> set interfaces interface eth9 ?
  description          enabled          ipv4
  ipv6                 link-up-down-trap-enable  type
user@host> set interfaces interface eth9 type ex:eth
user@host> validate
user@host> commit
user@host> show configuration xml
<interfaces xmlns="urn:ietf:params:xml:ns:yang:ietf-interfaces">
  <interface>
    <name>eth9</name>
    <type>ex:eth</type>
    <enabled>true</enabled>
  </interface>
</interfaces>
user@host> show configuration cli
set interfaces interface eth9
set interfaces interface eth9 type ex:eth
set interfaces interface eth9 enabled true
user@host> delete interfaces interface eth9
```

9.1.2 Command-line options

The *clixon_cli* client has the following command-line options:

-h	Help
-V	Show version and exit
-D <level>	Debug level
-f <file>	Clixon config file
-E <dir>	Extra configuration directory
-l <option>	Log on (s)yslog, std(e)rr, std(o)ut, (n)one or (f)ile. Stderr is default.
-C <format>	Dump configuration options on stdout after loading. Format is one of xml json text cli default
-F <file>	Read commands from file (default stdin)
-1	Run once, do not enter interactive mode
-s	Disable output scrolling
-a <family>	Internal IPC backend socket family: UNIX IPv4 IPv6
-u <path addr>	Internal IPC socket domain path or IP addr (see -a)
-d <dir>	Specify cli plugin directory
-m <mode>	Specify plugin syntax mode
-q	Quiet mode, do not print greetings or prompt, terminate on ctrl-C
-p <dir>	Add Yang directory path (see CLICON_YANG_DIR)
-G	Print auto-cli CLI syntax generated from YANG
-L	Debug print dynamic CLI syntax including completions and expansions
-y <file>	Load yang spec file (override yang main module)
-c <file>	Specify cli spec file
-U <user>	Over-ride unix user with a pseudo user for NACM.
-o <option=value>	Give configuration option overriding config file (see clixon-config.yang)

Inline CLI commands

CLI commands can be given directly after the options. These are executed directly:

```
clixon_cli -f example.xml show config
clixon_cli -f example.xml set table parameter b \; show config
```

Multiple commands are separated with `;`. One can also add extra application-dependent plugin options after `-` which can be read with *clixon_argv_get()*:

```
clixon_cli -f example.xml show config -- -x extra-option
```

9.2 9.2 Configure options

The following config options are related to clispec and plugin files (clixon config options), ie they are set in the XML Clixon config file:

CLICON_CLI_DIR

Directory containing frontend cli loadable plugins. Load all *.so* plugins in this directory as CLI object plugins.

CLICON_CLISPEC_DIR

Directory containing frontend cligen spec files. Load all *.cli* files in this directory as CLI specification files.

CLICON_CLISPEC_FILE

Specific frontend cligen spec file as alternative or complement to *CLICON_CLISPEC_DIR*. Also available as *-c* in *clixon_cli*.

CLICON_AUTOCLI_CACHE_DIR

Directory containing backend generated cligen spec files from YANG, see also *clispec-cache*

CLICON_NACM_AUTOCLI

Enable NACM rules for autocli. If set, the autocli will not expand commands the user does not have read-access to.

CLICON_CLI_PIPE_DIR

Directory where CLI pipe scripts or binaries are searched for in cli callback

CLICON_CLI_OUTPUT_FORMAT

Default CLI output format.

9.2.1 9.2.1 Terminal I/O

Clixon CLI have the following configuration options related to terminal I/O:

CLICON_CLI_LINESCROLLING

Set to *0* if you want CLI to wrap to next line. Set to *1* if you want CLI to scroll sideways when approaching right margin (default).

CLICON_CLI_LINES_DEFAULT Set to number of CLI terminal rows for pagination/scrolling. *0* means unlimited. The number is set statically UNLESS:

- there is no terminal, such as file input, in which case nr lines is *0*
- there is a terminal sufficiently powerful to read the number of lines from *ioctl* calls.

In other words, this setting is used **ONLY** on raw terminals such as serial consoles.

CLICON_CLI_TAB_MODE

Set CLI tab mode flags:

- Set bit 1 (0x01) if you want to has same output as *?*, ie line per command, otherwise short info of available commands
- Set bit 2 (0x02) if you want commands and variables to have same preference, otherwise select command
- Set bit 3 (0x04) if you want to complete multiple command levels at once, otherwise complete only one level per TAB
- Set bit 4 (0x08) if you want to complete and show available commands in one step, otherwise a second TAB shows alternatives. By default this bit is set.

9.2.2 9.2.2 History

Clixon CLI supports persistent command history. There are two CLI history related configuration options:

CLICON_CLI_HIST_FILE

The file containing the history, default value is: `~/clixon_cli_history`

CLICON_CLI_HIST_SIZE

Max number of history line, default value is 300.

The design is similar to bash history but is simpler in some respects:

- The CLI loads/saves its complete history to a file on entry and exit, respectively
- The size (number of lines) of the file is the same as the history in memory
- Only the latest session dumping its history will survive (bash merges multiple session history).

Further, tilde-expansion is supported and if history files are not found or lack appropriate access will not cause an exit but are logged at debug level

CLI command log

The history API also allows for adding CLI command logging. Register the callback in the plugin init, and then call logging (or debug) for each CLI command. Example:

```
static int
cli_history_cb(cligen_handle ch,
               char          *cmd,
               void          *arg)
{
    int          retval = -1;

    return clixon_log(arg, LOG_INFO, "command: %s", cmd);
}

clixon_plugin_api *
clixon_plugin_init(clixon_handle h)
{
    ...
    cligen_hist_fn_set(cli_cligen(h), cli_history_cb, h);
}
```

9.2.3 9.2.3 Help strings

Help strings are specified using the following example syntax: ("help string"). help strings are shown at queries, eg "?":

```
user@host> show <?>
  all      Show all
  routing  Show routing
  files    Show files
```

For long or multi-line help strings the following configure options exists:

CLICON_CLI_HELPSTRING_TRUNCATE

Set to 0 to wrap long help strings to the next line. (default) Set to 1 to truncate long help strings at the right margin

CLICON_CLI_HELPSTRING_LINES

Set to 0 to have no limit on the number of help string lines per command Set to <n> to limit the the number of help string lines

Long and multi-line help strings may especially be needed in the auto-cli, see *autocli*.

9.2.4 9.2.4 Modes

The CLI can have different *modes* which is controlled by a config option and some internal clispec variables. The config options are:

CLICON_CLI_MODE

Startup CLI mode. This should match a CLICON_MODE variable setting in one of the clispec files. Default is "base".

CLICON_CLI_VARONLY

Do not include keys in cvec in cli vars callbacks

Inside the clispec files CLICON_MODE is used to specify to which modes the syntax in a specific file defines. For example, if you have major modes *configure* and *operation* you can have a file with commands for only that mode, or files with commands in both, (or in all).

First, lets add a single command in the configure mode:

```
CLICON_MODE="configure";  
show configure;
```

Then add syntax to both modes:

```
CLICON_MODE="operation:configure";  
show("Show") files("Show files");
```

Finally, add a command to all modes:

```
CLICON_MODE="*";  
show("Show") all("Show all");
```

Note that CLI command trees are merged so that show commands in other files are shown together. Thus, for example, using the clispecs above the two modes are the three commands in total for the *configure* mode:

```
> clixon_cli -m configure  
user@host> show <TAB>  
all      routing      files
```

but only two commands in the *operation* mode:

```
> clixon_cli -m operation  
user@host> show <TAB>  
all      files
```

9.2.5 9.2.5 Cli-spec variables

A CLI specification file (note not clixon config file) typically starts with the following variables:

CLICON_MODE

A colon-separated list of CLIgen *modes*. The CLI spec in the file are added to *all* modes specified in the list. You can also use wildcards * and '?`.

CLICON_PROMPT

A string describing the CLI prompt using a very simple format with: %H (host) , %U (user) , %T (tty), %W (last element of working path), %w (full working path).

CLICON_PLUGIN

The name of the object file containing callbacks in this file.

CLICON_PIPETREE

Name of a pipe output tree as described in

9.3 9.3 Autocli

The Clixon CLI contains parts that are *generated* from a YANG specification. This *autocli* is generated from YANG into CLI specifications, parsed and merged into the top-level Clixon CLI.

The autocli is configured using three basic mechanisms:

1. *Config file* : Modify behavior of the generated tree
2. *Tree expansion*: How the generated cli is merged into the overall CLI
3. *YANG Extensions*: Modify CLI behavior via YANG

Each mechanism is described in sub-sections below, but first an overview of autocli usage.

9.3.1 9.3.1 Overview

Consider a (simplified) YANG specification, such as:

```
module example {
  container table {
    list parameter{
      key name;
      leaf name{
        type string;
      }
    }
  }
}
```

An example of a generated syntax is as follows (again simplified):

```
table; {
  parameter <name:string>;
}
```

The auto-cli syntax is loaded using a *sub-tree operator* such as @datamodel into the Clixon CLI as follows:

```
CLIXON_PROMPT="%U@%H %W> ";
set @datamodel, cli_auto_set();
merge @datamodel, cli_auto_merge();
delete @datamodel, @add:leafref-no-refer, @add:ac-strict-expand, cli_auto_del();
show config, cli_auto_show("datamodel", "candidate", "text", true, false);{
  @datamodel, cli_show_auto("candidate", "text");
}
```

For example, the *set* part is expanded using the CLIgen tree-operator to something like:

```
set table, cli_auto_set(); {
  parameter <name:string>, cli_auto_set();
}
```

An example run of the above example is as follows:

```
> clixon_cli
user@host /> set table ?
  <cr>
  parameter
user@host /> set table parameter 23
user@host /> show config
table {
  parameter {
    name 23;
  }
}
user@host />
```

where the generated autocli extends the Clixon CLI with YANG-derived configuration statements.

9.3.2 Operations

The autocli *set/merge/delete* commands are modelled after NETCONF operations as defined in the [NETCONF RFC](#), with the following (shortened) definition, and mapping to the autocli operations above):

- *merge*: (Autocli *merge*) The configuration data is merged with the configuration in the configuration datastore
- *replace*: (Autocli *set*) The configuration data replaces any related configuration in the configuration datastore.
- *create*: The configuration data is added to the configuration if and only if the configuration data does not already exist in the configuration datastore.
- *delete*: The configuration data is deleted from the configuration if and only if the configuration data currently exists in the configuration datastore.
- *remove*: (Autocli *delete*) The configuration data is deleted from the configuration if the configuration data currently exists in the configuration datastore. If the configuration data does not exist, the “remove” operation is silently ignored

In particular, the autocli *set* operation may cause some confusion. For terminals, i.e., CLI commands derived from YANG leaf or leaf-list, the behavior of “replace/set” and “merge” are identical. However for non-terminals (i.e., CLI commands derived from YANG container or list) “replace/set” and “merge” differ: “set” replaces the existing configuration. “Merge” merges the existing configuration.

Example, where x is (derived from) a container and y is (derived from) a leaf:

```

set x y 22
set x y 24      # Replace y: y changes value to 24
set x          # Replace x: y is removed
merge x y 26
merge x y 28    # Merge y: y changes value to 28
merge x        # Merge x: y still has value 28

```

Therefore, most users may want to use *merge* as default autocli operation, instead of *set*.

Note: Use autocli *merge* as default operation

9.3.3 9.3.3 Config file

The clixon config file has a `<autocli>` sub-clause for global autocli configurations. A typical CLI configuration with default autocli settings is as follows:

```

<clixon-config xmlns="http://clixon.org/config">
  <CLICON_CONFIGFILE>/usr/local/etc/clixon/example.xml</CLICON_CONFIGFILE>
  ...
  <autocli>
    <module-default>true</module-default>
    <list-keyword-default>kw-nokey</list-keyword-default>
    <treeref-state-default>>false</treeref-state-default>
    <edit-mode-default>list container</edit-mode-default>
    <completion-default>true</completion-default>
  </autocli>
</clixon-config>

```

The autocli configuration consists of a set of default *options*, followed by a set of *rules*. For more info see the `clixon-autocli.yang` specification.

Options

The following options set default values to the auto-cli, some of these may be further refined by successive rules.

module-default

How to generate the autocli from modules:

- If *true*, all modules with a top-level datanode are generated, ie they get a top-level entry in the `@baseModel` tree. You can explicitly disable modules. This is default
- If *false*, you need to explicitly enable modules for autocli generation using *module enable rules*.

list-keyword-default

How to generate the autocli from YANG lists. There are several variants defined. To understand the different variants, consider a simple YANG LIST definition as follows:

```

list a {
  key x;
  leaf x;
  leaf y;
}

```

The different variants with the resulting autocli are as follows:

- *kw-none* : No extra keywords, only variables: a <x> <y>
- *kw-nokey* : Keywords on non-key variables: a <x> y <y>. This is default.
- *kw-all* : Keywords on all variables: a x <x> y <y>

treeref-state-default

If generate autocli from YANG *state* data. The motivation for this option is that many specs have very large state parts. In particular, some openconfig YANG specifications have ca 10 times larger state than config parts.

- If *true*, generate CLI from YANG state/non-config statements, not only from config data.
- If *false* do not generate autocli commands from YANG state data. This is default.

edit-mode-default

Open automatic edit-modes for some YANG keywords and do not allow others. A CLI edit mode opens a carriage-return option and changes the context to be in that local context. For example:

```
user@host> interfaces interface e0<cr>
eth0>
```

Default is to generate edit-modes for all YANG containers and lists. For more info see [edit modes](#)

completion-default

Generate code for CLI completion of existing db symbols. That is, check existing configure database for completion options. This is normally always enabled.

grouping-treeref

Controls the behaviour when generating CLISPEC of YANG *uses* statements into the corresponding *grouping* definition. If *true*, use indirect tree reference @treeref to reference the grouping definition. This may reduce memory footprint of the CLI.

clispec-cache

Autocli cache mode for saving generated autocli clispecs between runs. Either *disabled* or *read*. Set to *read* to activate the cache, if so, the *CLICON_AUTOCLI_CACHE_DIR* must also be set in the backend.

Rules

To complement options, a set of rules to further define the autocli can be defined. Common rule fields are:

name

Arbitrary name assigned for the rule, must be unique.

operation

Rule operation, There are currently two operations defined: *module enable* and command *compress*.

module-name

Name of the module associated with this rule. Wildchars '*' and '?' can be used (glob pattern). Revision and yang suffix are omitted. Example: `openconfig-*`

Module enable rules

Module enable rules are used in combination with `module-default=false` to enable CLI generation for a limited set of YANG modules.

For example, assume you want to enable modules *example1*, *example2* and no others:

```
<autocli>
  <module-default>false</module-default>
  <rule>
    <name>include example</name>
    <operation>enable</operation>
    <module-name>example*</module-name>
  </rule>
</autocli>
```

If the option `module-default` is `true`, module enable rules have no effect since all modules are already enabled.

You can also disable all modules by default, and enable them individually, like the following example shows:

```
<autocli>
  <module-default>>true</module-default>
  <rule>
    <name>exclude example 2</name>
    <operation>disable</operation>
    <module-name>example2</module-name>
  </rule>
</autocli>
```

Likewise, disable rules have no effect if `module-default` is `false`.

Compress rules

Compress rules are used to skip CLI commands, making the complete command name shorter.

For example, assume YANG definition:

```
container interfaces {
  list interface {
    ...
  }
}
```

Instead of typing `interfaces interface e0` you would want to type only `interface e0`. The following rule matches all YANG containers with lists as its only child, and removes the keyword `interfaces`:

```
<rule>
  <name>compress</name>
  <operation>compress</operation>
  <yang-keyword>container</yang-keyword>
  <yang-keyword-child>list</yang-keyword-child>
</rule>
```

Note that this matches the openconfig compress rule: [The surrounding ‘container’ entities are removed from ‘list’ nodes](#)

A second openconfig compress rule is The ‘config’ and ‘state’ containers are “compressed” out of the schema. as exemplified here (for ‘config’ only):

```
<rule>
  <name>openconfig compress</name>
  <operation>compress</operation>
  <yang-keyword>container</yang-keyword>
  <schema-nodeid>config</schema-nodeid>
  <module-name>openconfig*</module-name>
</rule>
```

Specific fields for compress are:

yang-keyword

If present identifies a YANG keyword which the rule applies to. Example: container

schema-nodeid

A single <id> identifying a YANG schema-node identifier as defined in RFC 7950 Sec 6.5. Example: config

yang-keyword-child

The YANG statement has a single child, and the yang type of the child is the value of this option. Example: : container

extension

The extension is set either in the node itself, or in the module the node belongs to. Extension prefix must be set. Example: oc-ext:openconfig-version

9.3.4 9.3.4 Tree expansion

In the example above, the tree-reference @datamodel is used to merge the YANG-generated cli-spec into the overall cli-spec. There are several variants of how the generated tree is expanded with slight differences in which symbols are shown, how completion works, etc.

They are all derivatives of the basic @basemodel tree. The following tree variants are defined:

- @basemodel - The most basic tree including everything
- @datamodel - The most common tree for configuration with state
- @datamodelshow - A tree made for showing configuration syntax
- @datamodelmode - A tree for editing modes
- @datamodelstate - A tree for showing state as well as configuration

Note to use @datamodelstate config option treeref-state-default must be set.

9.3.5 9.3.5 YANG Extensions

A third method to define the autocli is using *YANG extensions*, where a YANG specification is annotated with extension.

Clixon provides a dedicated YANG extension for the autocli for this purpose: clixon-lib:autocli.

The following example shows the main example usage of the “hide” extension of the “hidden” leaf:

```
import clixon-autocli{
  prefix autocli;
}
```

(continues on next page)

(continued from previous page)

```

container table{
  list parameter{
    ...
    leaf hidden{
      type string;
      autocli:hide;
    }
  }
}

```

The CLI hidden command is not shown but the command still exists:

```

cli /> set table parameter a ?
value
<cr>
cli /> set table parameter a hidden 99
cli /> show configuration
table {
  parameter {
    name a;
    hidden 99;
  }
}

```

The following autocli extensions are defined:

hide

Do not show the command in eg auto-completion. This was primarily intended for operational commands such as `start shell` but in this context used for hiding commands generated from the associated YANG node.

hide-show

Do not show the config in show configuration commands. However, retrieving a config via NETCONF or examining the datastore directly shows the hidden configure commands.

skip

Skip the command altogether.

strict-expand

Only show exactly the expanded options of a variable. It should not be possible to add a *new* value that is not in the expanded list. See also `ac-strict-expand` in Section [Autocli tree labels](#).

alias

Replace the command with another value, only implemented for YANG leaves.

9.3.6 9.3.6 Edit modes

The autocli supports *automatic edit modes* where by entering a `<cr>`, you enter an edit mode. An edit mode is created for every YANG container or list.

For example, the example YANG previously given and the following cli-spec:

```

edit @datamodelmode, cli_auto_edit("basemodel");
up, cli_auto_up("basemodel");
top, cli_auto_top("basemodel");
set @datamodel, cli_auto_set();

```

Then an example session for illustration is as follows, where first a small config is created, then a list instance mode is entered (parameter a), a value changed, and a container mode (table):

```
user@host /> set table parameter a value 42
user@host /> set table parameter b value 77
user@host /> edit table parameter a
user@host parameter=a/>
user@host parameter=a/> show configuration
  name a;
  value 42;
user@host parameter=a/> set value 99
user@host parameter=a/> up
user@host table> show configuration
parameter {
  name a;
  value 99;
}
parameter {
  name b;
  value 77;
}
user@host table> top
user@host />
```

9.3.7 9.3.7 NACM for autocli

When NACM is enabled, the autocli can be configured to hide CLI commands that the current user does not have read access to. This is controlled by the CLICON_NACM_AUTOCLI option and requires `clispec-cache=read autocli mode` (see *Config file*).

For a general introduction to NACM, see the *NACM* documentation.

Overview

When CLICON_NACM_AUTOCLI is true, the CLI fetches the NACM rules for the current user from the backend at startup. During tab-completion and ?-expansion, any YANG data node whose schema path is covered by a NACM deny rule (or is not covered by a permit rule when `read-default` is `deny`) is silently hidden from the completion list.

Two NACM `read-default` policies are supported:

permit (default)

All nodes are visible unless an explicit `deny` rule matches. Only the denied nodes are hidden.

deny

All nodes are hidden unless an explicit `permit` rule matches. Ancestors of permitted nodes are shown so the user can navigate down to them; descendants of permitted nodes are also shown.

Note: NACM autocli filtering is a *cosmetic* aid: the backend still enforces full NACM access control on every datastore operation. A user who crafts a command bypassing the autocli will still be denied by the backend.

Configuration

Enable NACM autocli by adding the following to the Clixon config file:

```
<CLICON_NACM_AUTOCLI>true</CLICON_NACM_AUTOCLI>
```

The autocli cache must be set to read mode (the CLI fetches clispecs from the backend, which allows per-user NACM filtering):

```
<autocli>
...
<clispec-cache>read</clispec-cache>
</autocli>
```

Disable NACM autocli filtering on a per-invocation basis with the `-o` command-line option:

```
clixon_cli -o CLICON_NACM_AUTOCLI=false
```

Example

Consider a YANG model with top-level containers `public` and `secret`, and the following NACM configuration that permits all reads but explicitly denies `/secret` for the `limited` group:

```
<nacm xmlns="urn:ietf:params:xml:ns:yang:ietf-netconf-acm">
  <enable-nacm>true</enable-nacm>
  <read-default>permit</read-default>
  <rule-list>
    <name>limited-acl</name>
    <group>limited</group>
    <rule>
      <name>deny-secret</name>
      <module-name>*</module-name>
      <path xmlns:ex="urn:example"/>ex:secret</path>
      <access-operations>read</access-operations>
      <action>deny</action>
    </rule>
  </rule-list>
</nacm>
```

A user in the `limited` group sees only `public` at tab-completion:

```
limited@host /> set ?
public    Public configuration
```

An admin user sees both:

```
admin@host /> set ?
public    Public configuration
secret    Secret configuration
```

The same filtering applies in edit mode. If the user navigates into a container and then types `set ?`, only the sub-nodes that are permitted by NACM are shown.

9.4 9.4 CLI callbacks

CLI callback functions are “library” functions that an application may call from a clispec. A user is expected to create new application-specific callbacks.

There are two major types of CLI callbacks:

1. Command callbacks, to implement the semantics of a CLI command
2. Expand callbacks, for providing a set of values to a variable

9.4.1 9.4.1 Command callbacks

A CLI command callback is invoked as a result of a command and implements its semantics, and is given as the last statement in a command.

Clixon provides several command callbacks, but a developer typically adds new commands applicable for the application.

Consider the following clispec example of the command callback `mycallback()`:

```
example("Callback example") <var:int32>("any number"), mycallback("myarg");
```

The example contains a keyword (*example*) and a variable (*var*), while *mycallback* is the CLI callback with argument: (*myarg*).

In C, the callback has the following signature:

```
int mycallback(clixon_handle h, cvec *cvv, cvec *argv);
```

Suppose a user enters the following command in the CLI:

```
user@host> example 23
```

The callback is called with the following parameters:

```
cvv:
  0: example 23
  1: 23
argv:
  0: "myarg"
```

which means that *cvv* contains dynamic values set by the user, and *argv* contains static values set by the clispec designer.

9.4.2 9.4.2 Expand callbacks

Some variables may need a dynamic set of values to choose from, for example, currently existing interface names.

An expand callback is always given *inside* a variable declaration.

Clixon currently provides the following set of expand callbacks:

- `expand_dbvar()`: finding datastore symbols
- `expand_dir()`: for files in a directory
- `expand_yang_list()`: finding YANG symbols

Just like command callbacks, a developer can add new expand functions.

An example of finding datastore symbols in the *candidate* datastore:

```
table parameter <var:int32 expand_dbvar("candidate", "/clixon-example:table/parameter=%s/
↳value")>
```

where the second argument is an *api-path* (see Section *Api-path-fmt*) defining a datastore object.

Example, assume there are two table parameters in the candidate datastore:

```
cli> table parameter <?>
  a      Table paramter
  b      Table parameter
```

Expanding leafrefs

When completing a leafref variable, the CLI can either expand using the *referred* node (the leafref target path), or expand using the *existing* values in the datastore (the node itself).

The behavior depends on how `expand_dbvar()` is used:

Autocli-generated clispec (@datamodel / @tree):

The autocli generator automatically adds a `leafref-refer` label to variables whose YANG type is `leafref` or `union` (possibly containing leafrefs). This causes `expand_dbvar()` to follow the leafref and offer values from the referred node.

To suppress this and expand from the existing values instead, add the `leafref-no-refer` label, typically via `@add:leafref-no-refer`:

```
set @tree, cli_add();
delete @tree, @add:leafref-no-refer, cli_delete();
```

This results in the following behavior for adding and removing leafrefs, respectively:

- `set`: expands to values in the referred node (e.g. `parameter/name`)
- `delete`: expands to the existing values in the datastore (what is actually stored)

Manually crafted clispec:

`expand_dbvar()` defaults to **not** following leafrefs (`leafref-refer=false`). This is correct for most manual CLI commands that want to expand from existing datastore values, not from a leafref target.

To opt into leafref following in a manual clispec, add the `leafref-refer` label explicitly:

```
set leafref <var:string leafref-refer expand_dbvar("candidate", "/ex:list/leafref")>
↳;
delete leafref <var:string expand_dbvar("candidate", "/ex:list/leafref")>;
```

In summary:

Scenario	leafref-refer	leafref-no-refer	Result
Autocli, leafref/union type	set by generator	absent	follows leafref ✓
Autocli + @add:leafref-no-refer	set by generator	set by @add	uses existing values ✓
Manual clispec (default)	absent	absent	uses existing values ✓
Manual clispec + leafref-refer	set explicitly	absent	follows leafref ✓

Assume the following YANG:

```
list parameter{
  key name;
  leaf name{
    description "referred node";
    type string;
  }
}
leaf-list leafref{
  description "referring node";
  type leafref{
    path "../parameter/name";
  }
}
```

Example using autocli tree references:

```
set @tree, cli_add();
delete @tree, @add:leafref-no-refer, cli_delete();
```

This results in the following behavior for adding and removing leafrefs, respectively:

```
cli> set parameter a
cli> set parameter b
cli> set leafref ?
  a
  b
cli> set leafref a
cli> set leafref c
cli> delete leafref ?
  a
  c
cli>
```

In other words, when adding new nodes, the CLI expands to referred, original values (“a” and “b”), but when deleting nodes, the actual values, non-referred (“a” and “c”) are offered as potential choices.

9.5 9.5 Show commands

Clixon includes show commands for showing datastore and state content. An application may use these functions as basis for more specialized show functions. Some show functions are:

- `cli_show_config()` - Multi-purpose show function for manual CLI show commands
- `cli_show_auto()` - Used in conjunction with the autocli with expansion trees
- `cli_show_auto_mode()` - Used in conjunction with the autocli with edit-modes
- `cli_pagination()` - Show paginated data of a large list

The CLI show functions are utility functions in the sense that they are not part of the core functionality and a user or product may want to specialize them.

Note: CLI library functions are subject to change in new releases

9.5.1 9.5.1 cli_show_config

The `cli_show_config` is a basic function to display datastore and state data. A typical use in a cli spec is as follows:

```
show("Show configuration"), cli_show_config("candidate", "text");
```

Using this command in the CLI could provide the following output:

```
cli> show
<table xmlns="urn:example:clixon">
  <parameter>
    <name>a</name>
    <value>x</value>
  </parameter>
</table>
```

The callback has the following parameters, only the first is mandatory:

- *dbname* : Name of datastore to show, such as “running”, “candidate” or “startup”
- *format* : Show format, one of *text*, *xml*, *json*, *cli*, *netconf*, or *default* (see *datastore formats*)
- *xpath* : Static xpath (only present in this API function)
- *namespace* : Default namespace for xpath (only present in this API function)
- *pretty* : If *true*, make output pretty-printed
- *state* : If *true*, include non-config data in output
- *default* : Optional default retrieval mode: one of *report-all*, *trim*, *explicit*, *report-all-tagged*. See also extended values below
- *prepend* : Optional prefix to prepend before cli syntax output, only valid for CLI format.
- *fromroot* : If *false* show from xpath node, if *true* show from root

9.5.2 9.5.2 cli_show_auto

The `cli_show_auto()` callback is used together with the `autocli` to show sub-parts of a configured tree using expansion. A typical definition is as follows:

```
show("Show expand") @datamodelshow, cli_show_auto("candidate", "xml");
```

That is, it must always be used together with a tree-reference as described in Section *autocli*.

An example CLI usage is:

```
cli> show table parameter a
<parameter>
  <name>a</name>
  <value>x</value>
</parameter>
```

The arguments are similar to `cli_show_config` with the difference that the `xpath` is implicitly defined by the current position of the tree reference:

```
* `dbname` : Name of datastore to show, such as "running", "candidate" or "startup"
* `format` : Show format, one of `text`, `xml`, `json`, `cli`, `netconf`, or `default`
↳(see :ref:`datastore formats <clicon_datastore>`)
* `pretty` : If `true`, make output pretty-printed
* `state` : If `true`, include non-config data in output
* `default` : Optional default retrieval mode: one of `report-all`, `trim`, `explicit`,
↳`report-all-tagged`. See also extended values below
* `prepend` : Opional prefix to print before cli syntax output, only valid for CLI
↳format.
```

9.5.3 9.5.3 cli_show_auto_mode

The `cli_show_auto_mode()` callback also used together with the `autocli` but instead of expansion uses the edit-modes (see Section *edit modes*). A typical definition is:

```
show, cli_show_auto_mode("candidate");
```

An example usage using edit-modes is:

```
cli> edit table
cli> show
<parameter>
  <name>a</name>
  <value>x</value>
</parameter>
```

Same parameters as `cli_show_auto`

9.5.4 9.5.4 cli_start_program

You need to add a callback and its name in the `.cli` file.

Here is an example of how you can do it:

```
run_program_err("Run program"), cli_start_program();
run_program_python3("Run program"), cli_start_program("python3");
run_program_python3_source_arg("Run program"), cli_start_program("python3", "/tmp/test.py
↳");
run_program_python3_source_arg_vector("Run program") <source:rest>("Path program"), cli_
↳start_program("python3");
run_program_python3_source_arg_vector_err("Run program") <source:rest>("Path program"),
↳cli_start_program("python3", "/tmp/test2.py");
run_program_bash("Run program"), cli_start_program("bash");
```

What the above-described callbacks do:

Starts a new process and the specified program in it. The function creates a new child process and starts the specified program in it. Before starting the program in the child process, environment variables are set from the `cvv`. The function checks the parameters passed to it. Situations where at least one function argument is absent or when two arguments are present both in the function and in the `cvv` vector are considered invalid.

`run_program_python3_source_arg_vector_err` will fail because you can either enter interactively or write in a call:

```
roma@f-15 /> run_program_python3_source_arg_vector_err /tmp/test.py
Aug 14 08:52:47.375126: cli_start_program: 830: Plugins: A lot of arguments: Invalid.
↪argument
CLI command error
```

`run_program_err` will fail because there are no parameters:

```
user@pc_name /> run_program_err
Aug 14 08:37:41.386765: cli_start_program: 826: Plugins: Can not found argument in a.
↪function: Invalid argument
CLI command error
```

`run_program_bash` executes `bash`:

```
user@pc_name /> run_program_bash
user_pc@pc_name:~#
```

`run_program_python3` runs `python3`:

```
user@pc_name /> run_program_python3
Python 3.11.2 (main, May 2 2024, 11:59:08) [GCC 12.2.0] on linux
Type "help", "copyright", "credits" or "license" for more information.
>>>
```

`run_program_python3_source_arg` runs `/tmp/test.py` using `python3`.

`/tmp/test.py` file

```
#!/usr/bin/python3
print("Hello world! :)")
```

Run:

```
user@pc_name /> run_program_python3_source_arg
Hello world! :)
user@pc_name />
```

`run_program_python3_source_arg_vector` entails interactive input of the filename

```
user@pc_name run_program_python3_source_arg_vector /tmp/test.py
Hello world! :)
user@pc_name />
```

9.5.5 9.5.5 Common show parameters

with-default parameter

All show commands have an optional *with-default* retrieval mode: one of *report-all*, *trim*, *explicit*, *report-all-tagged*. There are also extra proprietary modes of *default* serving as examples:

- *NULL*, default with-default value, usually *report-all*
- *report-all-tagged-default*, which gets the config as *report-all-tagged* but strips the tags/attributes (same as *report-all*).
- *report-all-tagged-strip*, which also gets the config as *report-all-tagged* but strips the nodes associated with the default tags (same as *trim*).

pretty parameter

All show commands have a pretty-print parameter. If *true* the output is pretty-printed. Indentation level is controlled by the `PRETTYPRINT_INDENT` compile-time option

9.6 9.6 Load and save commands

Clixon provides utility callbacks to load configuration from a file into the candidate datastore and to save a datastore to a file. These callbacks are typically used in CLI spec files together with a filename argument.

9.6.1 9.6.1 load_config_file

`load_config_file` reads a configuration file and sends its content to the backend as an `edit-config` operation on the candidate datastore. In a typical `clispec` the operation and format are exposed as nested sub-commands:

```
load("Load configuration") <filename:string>("Filename"), load_config_file("filename",
↪ "replace");{
    replace("Replace candidate with file contents"), load_config_file("filename",
↪ "replace");{
        xml("Replace candidate with XML file"), load_config_file("filename", "replace",
↪ "xml");
        json("Replace candidate with JSON file"), load_config_file("filename", "replace",
↪ "json");
        text("Replace candidate with text file"), load_config_file("filename", "replace",
↪ "text");
        cli("Replace candidate with CLI file"), load_config_file("filename", "replace",
↪ "cli");
    }
    merge("Merge file with existing candidate"), load_config_file("filename", "merge");{
        xml("Merge XML file into candidate"), load_config_file("filename", "merge", "xml
↪");
        json("Merge JSON file into candidate"), load_config_file("filename", "merge",
↪ "json");
        text("Merge text file into candidate"), load_config_file("filename", "merge",
↪ "text");
        cli("Merge CLI file into candidate"), load_config_file("filename", "merge", "cli
```

(continues on next page)

(continued from previous page)

```
↪");
  }
}
```

This produces a command hierarchy where the operation and format are optional sub-commands:

```
> load /path/to/file           # replace, xml (defaults)
> load /path/to/file merge     # merge, xml (default format)
> load /path/to/file merge json # merge, json
```

The callback takes the following arguments:

- `varname` : Name of the CLIgen variable that holds the filename, as given on the command line.
- `operation` : Either `merge` (merge file content with the existing candidate) or `replace` (replace the entire candidate with the file content).
- `format` : Optional. One of `xml` (default), `json`, `text`, `cli`, or `netconf`.

9.6.2 9.6.2 save_config_file

`save_config_file` retrieves the content of a datastore and writes it to a local file. A typical CLI spec entry is:

```
save("Save configuration") <filename:string>("Filename"), save_config_file("running",
↪"filename", "json");
```

The callback takes the following arguments:

- `dbname` : The datastore to read from: `running`, `candidate`, or `startup`.
- `varname` : Name of the CLIgen variable holding the output filename.
- `format` : Optional. One of `xml` (default), `json`, `text`, `cli`, or `netconf`.

The saved file can be reloaded with `load_config_file` using the same format.

9.7 9.7 Output pipes

Output pipes resemble UNIX shell pipes and are useful to filter or modify CLI output. Example:

```
cli> print all | grep parameter
<parameter>5</parameter>
<parameter>x</parameter>
cli> show config | showas json
{
  "table": {
    "parameter": [
      ...
    ]
  }
}
cli>
```

Output pipe functions are declared using a special variant of a CLI tree with a name starting with a *vertical bar*. Example:

```
CLICON_MODE="|mypipe";
\| {
  grep <arg:rest>, pipe_grep_fn("-e", "arg");
  showas json, pipe_json_fn();
}
```

where `pipe_grep_fn` and `pipe_json_fn` are special callbacks that use `stdio` to modify output.

Such a pipe tree can be referenced with either an explicit reference, or an implicit rule.

Only a single level of pipes is possible in this release. For example, `a|b|c` is *not* possible.

Note: Only one level of pipes is supported

9.7.1 9.7.1 Explicit reference

An explicit reference is for single commands. For example, adding a pipe to the `print` commands:

```
print, print_cb("all");{
  @|mypipe, print_cb("all");
  all @|mypipe, print_cb("all");
  detail;
}
```

where a pipe tree is added as a tree reference, appending pipe functions to the regular `print_cb` callback. Note that the following commands are possible in this example:

```
print
print | count
print all | count
print detail
```

9.7.2 9.7.2 Implicit rule

An implicit rule adds pipes to *all* commands in a cli mode. An example of an implicit rule is as follows:

```
CLICON_PIPETREE="|mypipe";
print, print_cb("all");{
  all, print_cb("all");
  detail, print_cb("detail");
}
```

where the pipe tree is added implicitly to all commands in that file, and possibly on other files with the same mode.

Pipe trees also work for sub-trees, ie a subtree referenced by the top-level tree may also use output pipes.

9.7.3 9.7.3 Combinations

It is possible to combine an implicit (default) rule with an explicit rule as follows:

```
CLICON_MODE="|commonpipe";
print, print_cb("all");{
  @|mypipe, print_cb("all");
  all @|mypipe, print_cb("all");
  detail;
}
```

In this example, *print* and *print all* use the *mypipe* menu, while *print detail* uses the *|common* menu

9.7.4 9.7.4 Inheriting

Sub-trees inherit pipe commands from the top-level according to the following rules:

1. Top-level implicit rules are inherited to all sub-trees, unless
2. Explicit rules are present at the tree-reference
3. No pipe commands are allowed in a pipe-command (only single level allowed)

Rules 1 and 2 are illustrated as follows:

```
CLICON_MODE="|commonpipe";
aaa {
  @datamodel, cli_show();
  @|mypipe, cli_show();
}
bbb {
  @datamodel, cli_show();
}
```

Pipe commands in the *datamodel* tree are *|mypipe* if preceeded by *aaa*, but *|commonpipe* if preceeded by *bbb*

9.7.5 9.7.5 Generic pipe functions

You can write own scripts and use them as output pipe functions by placing them in *CLICON_CLI_PIPE_DIR*.

Assume for example that *CLICON_CLI_PIPE_DIR=/usr/local/lib/controller/pipes*, and that a script *first.sh* is placed in that dir, with the following content:

```
#!/usr/bin/env bash
head -1
```

Then add a pipe command as follows:

```
generic("Generic callbacks") <callback:string expand_dir("/usr/local/lib/controller/pipes
↵", "\.sh$")>("Callback"), pipe_generic("callback");
```

Then, start the CLI:

```
cli> show config | generic ?
first.sh
cli> show config | generic first.sh
<config>
cli>
```

9.8 9.8 CLI aliases

Clixon provides a simple API for creating CLI aliases.

Three clispec utility functions exists that create and show aliases as follows:

1. `cli_alias_add` : Add a constant alias command by specifying name and command
2. `cli_aliasref_add` : Add an alias command by using completion
3. `cli_alias_show` : Show aliases

An example clispec using these three functions:

```
alias("Define alias function") <name:string>("Name of alias") <command:rest>("Alias_
↳commands"), cli_alias_add("name", "command");
aliasref("Define alias function using completion") <name:string>("Name of alias")_
↳@example, cli_aliasref_add("name");
show("Show a particular state of the system") alias, cli_alias_show();
```

Example of setting a CLI alias, invoking it, and showing its definition:

```
cli> alias cmd show config
cli> cmd
<table>
  <parameter/>
</table>
cli> show alias
cmd: show config
cli>
```

9.8.1 9.8.1 Restrictions

The alias API is limited and an application developer may need to modify or extend these functions when integrating aliases into a system. These cases include:

1. Saving aliases persistently, eg an src file.
2. Adding help-texts
3. Mode/tree support

9.9 9.9 Advanced

This section describes some advanced options in the Clixon CLI not described elsewhere.

9.9.1 9.9.1 Backend socket

By default, the CLI uses a UNIX socket as an IPC to communicate with the backend. It is possible to use an IP socket but with a restricted functionality, see *backend section*.

Start session

The session creation is “lazy” in the sense that a NETCONF session is only established when needed. After the session has been established, it is maintained (cached) by the CLI client to keep track of candidate edits and locks, as described in 7.5 of RFC 6241.

If there is no backend running at the time of session establishment, a warning is printed:

```
cli /> show config
Mar 18 11:53:43: clicon_rpc_connect_unix: 541: Protocol error: /usr/local/var/example/
↪example.sock: config daemon not running?: No such file or directory
Protocol error: /usr/local/var/example/example.sock: config daemon not running?: No such
↪file or directory
cli />
```

If at a later time, the backend is started, the session is established normally

Close session

After a session is established and the *backend* exits, crashes or restarts, any state associated with the session will be lost, including:

- explicit locks
- edits in candidate-db

If the backend exits during an existing session, it will close with the same error message as above:

```
cli /> show config
Mar 18 11:53:43: clicon_rpc_connect_unix: 541: Protocol error: /usr/local/var/example/
↪example.sock: config daemon not running?: No such file or directory
Protocol error: /usr/local/var/example/example.sock: config daemon not running?: No such
↪file or directory
cli />
```

If the backend restarts, a new session is created with a warning:

```
cli /> show configuration
Mar 18 11:57:55: The backend was probably restarted and the client has reconnected to
↪the backend. Any locks or candidate edits are lost.
cli />
```

Alternative

It is possible to change the default behavior by undefining the compile-option: `#undef PROTO_RESTART_RECONNECT`. If so, the CLI is exited when the existing session is closed in anyway:

```
cli /> show configuration
Mar 18 12:02:57: clixon_rpc_msg: 210: Protocol error: Unexpected close of CLICON_SOCKET.
↳Clixon backend daemon may have crashed.: Cannot send after transport endpoint shutdown
Protocol error: Unexpected close of CLICON_SOCKET. Clixon backend daemon may have crashed.
↳: Cannot send after transport endpoint shutdown
bash#
```

9.9.2 9.9.2 Sub-tree operator

Sub-trees are defined using the tree operator `@`. Every mode gets assigned a tree which can be referenced as `@name`. This tree can be either on the top-level or as a sub-tree. For example, create a specific sub-tree that is used as sub-trees in other modes:

```
CLICON_MODE="subtree";
subcommand{
  a, a();
  b, b();
}
```

then access that subtree from other modes:

```
CLICON_MODE="configure";
main @subtree;
other @subtree,c();
```

The configure mode will now use the same subtree in two different commands. Additionally, in the *other* command, the callbacks are overwritten by *c*. That is, if *other a*, or *other b* is called, callback function *c* is invoked.

9.9.3 9.9.3 Translators

CLIGen supports wrapper functions that can take the output of a callback and transform it to something else.

The CLI can perform variable translation. This is useful if you want to process the input, such as hashing, encrypting or in other way translate the input.

The following example is based on the main Clixon example and is included in the regression tests. In the following CLI specification, a “translate” command sets a modified value to the “table/parameter=translate/value”:

```
translate <value:string translate:cli_incstr(>, cli_set("/clixon-example:table/
↳parameter=translate/value");
```

If you run this example using the `cli_incstr()` function which increments the characters in the input, you get this result:

```
user@host> translate HAL
user@host> show configuration
table {
  parameter {
    name translate;
```

(continues on next page)

(continued from previous page)

```

    value IBM;
  }
}

```

The example is very simple and based on strings, but can be used also for other types and more advanced functions.

9.9.4 9.9.4 Autocli tree labels

The autocli trees described in *tree expansion* are implemented using filtering of CLIgen labels. While @basemodel includes all labels, the other trees have removed some labels.

For most uses, the pre-defined trees above are enough, using explicit label filtering is more powerful.

The currently defined labels are:

- `act-list` : Terminal entries of YANG LIST nodes.
- `act-container` : Terminal entries of YANG CONTAINER nodes.
- `ac-leaf` : Leaf/leaf-list nodes
- `act-prekey` : Terminal entries of LIST leaf keys, except the last keys in multi-key cases.
- `act-lastkey` : Terminal entries of LIST leaf keys, except the last keys in multi-key cases.
- `act-leafconst` : Terminal entries of non-empty non-key YANG LEAF/LEAF_LISTs command nodes.
- `act-leafvar` : Terminal entries of non-key YANG LEAF/LEAF_LISTs variable nodes.
- `ac-state` : Nodes which have YANG config `false` as child
- `ac-config` : Nodes which do not have any state nodes as siblings
- `ac-strict-expand` : Only show exactly the expanded options of a variable.

Labels with prefix `act_` are *terminal* labels in the sense that they mark a terminal command, ie the node itself; while labels with `ac_` represent the non-terminal, ie the whole sub-tree.

As an example, the @datamodel tree is basemodel with labels removed as follows:

```
@basemodel, @remove:act-prekey, @remove:act-list, @remove:act-leaf, @remove:ac-state;
```

which is an alternative way of specifying the datamodel tree.

Example: strict-expand

One example of the `strict-expand` label is to remove all general variable options for some trees and keep them for others. For example, one may need to set a new unknown value to a variable, but when deleting, it may not make sense to delete a non-existing value:

```
delete @datamodel, @add:ac-strict-expand, cli_auto_del();
set @datamodel, cli_auto_set();
```

In the cli:

```
# clixon_cli
cli /> set table parameter ?
a
b
<name>
cli /> delete table parameter ?
a
b
cli />
```

Note the absence of `<name>` in the delete rule.

9.9.5 9.9.5 Extensions to CLigen

Clixon adds some features and structure to CLigen which include:

- A plugin framework for both textual CLI specifications (.cli) and object files (.so)
- Object files contains compiled C functions referenced by callbacks in the CLI specification. For example, in the cli spec command: `a.fn()`, `fn` must exist in the object file as a C function.
- The CLigen `tree_name` syntax does not work.
- A CLI specification file is enhanced with the CLigen variables `CLICON_MODE`, `CLICON_PROMPT`, `CLICON_PLUGIN` and `CLICON_PIPETREE`.
- Clixon generates a command syntax from the Yang specification that can be referenced as `@datamodel`. This is useful if you do not want to hand-craft CLI syntax for configuration syntax.

Example of `@datamodel` syntax:

```
set @datamodel, cli_set();
merge @datamodel, cli_merge();
create @datamodel, cli_create();
show @datamodel, cli_show_auto("running", "xml");
```

The commands (eg `cli_set`) will be called with the first argument an api-path to the referenced object.

9.9.6 9.9.6 Running CLI scripts

The CLI can run scripts using either the `-1` option for single commands:

```
clixon_cli -1 show version
4.8.0.PRE
```

Or using the `-F <file>` command-line option to redirect input from file

```
clixon_cli -F file
```

Or using “shebang”:

```
#!/usr/local/bin/clixon_cli -F
show version
quit
```

Two caveats regarding “shebang”:

1. The clixon config file is `/usr/local/etc/clixon.xml`
2. The mode is `CLICON_CLI_MODE`

You may mod this by using soft links or creating a new executable to use use in the “shebang” with other default values.

9.9.7 9.9.7 How to deal with large specs

CLIGen is designed to handle large specifications in runtime, but it may be difficult to handle large specifications from a design perspective.

Here are some techniques and hints on how to reduce the complexity of large CLI specs:

Sub-modes

The `CLICON_MODE` is used to specify in which modes the syntax in a specific file should be added. For example, if you have major modes `configure` and `operation` you can have a file with commands for only that mode, or files with commands in both, (or in all).

First, lets add a basic set in each:

```
CLICON_MODE="configure";
show configure;
```

and:

```
CLICON_MODE="operation";
show configure;
```

Note that CLI command trees are *merged* so that show commands in other files are shown together. Thus, for example:

```
CLICON_MODE="operation:files";
show("Show") files("files");
```

will result in both commands in the operation mode:

```
> clixon_cli -m operation
user@host> show <TAB>
  configure      files
```

but:

```
> clixon_cli -m configure
user@host> show <TAB>
  configure
```

Sub-trees

You can also use sub-trees and the tree operator @. Every mode gets assigned a tree which can be referenced as @*name*. This tree can be either on the top-level or as a sub-tree. For example, create a specific sub-tree that is used as sub-trees in other modes:

```
CLICON_MODE="subtree";
subcommand{
  a, a();
  b, b();
}
```

then access that subtree from other modes:

```
CLICON_MODE="configure";
main @subtree;
other @subtree,c();
```

The configure mode will now use the same subtree in two different commands. Additionally, in the *other* command, the callbacks will be overwritten by *c*. That is, if *other a*, or *other b* is called, callback function *c* will be invoked.

C-preprocessor

You can also add the C preprocessor as a first step. You can then define macros, include files, etc. Here is an example of a Makefile using cpp:

```
C_CPP    = clispec_example1.cpp clispec_example2.cpp
C_CLI    = $(C_CPP:.cpp=.cli)
CLIS     = $(C_CLI)
all:     $(CLIS)
%.cli : %.cpp
        $(CPP) -P -x assembler-with-cpp $(INCLUDES) -o $@ $<
```

9.9.8 9.9.8 Bits

The Yang bits built-in type as defined in RFC 7950 Sec 9.7 provides a set of bit names. In the CLI, the names should be given in a white-spaced delimited list, such as "fin syn rst".

The RFC defines a “canonical form” where the bits appear ordered by their position in YANG, but Clixon validation accepts them in any order.

Given them in XML and JSON follows thus, eg XML:

```
<flags>fin rst syn</flags>
```

Clixon CLI does not treat individual bits as “first-level objects”. Instead it only validates the whole string of bit names. Operations (add/remove) are made atomically on the whole string.

9.9.9 9.9.9 Api-path-fmt

The clixon CLI uses an internal meta-format called `api_path_fmt` which is used to generate api-paths, as described in Section *XML*.

An `api-path-fmt` extends an `api-path` with % flag characters (like `printf`) as follows:

- %s: The value of a `cligen`-variable
- %k: The key of a YANG list

Example, an explicit `clispec` expansion variable could be:

```
<name:string expand_dbvar("candidate", "/interface=%s/%k")>
```

which could expand to `/interface=eth0/mykey` if “eth0” is given as the “name” variable and “mykey” is the YANG interface list key.

10 NETCONF

10.1 10.1 Overview

Netconf is an external client interface (cli and restconf are other external interfaces). Netconf is also used in the internal IPC.

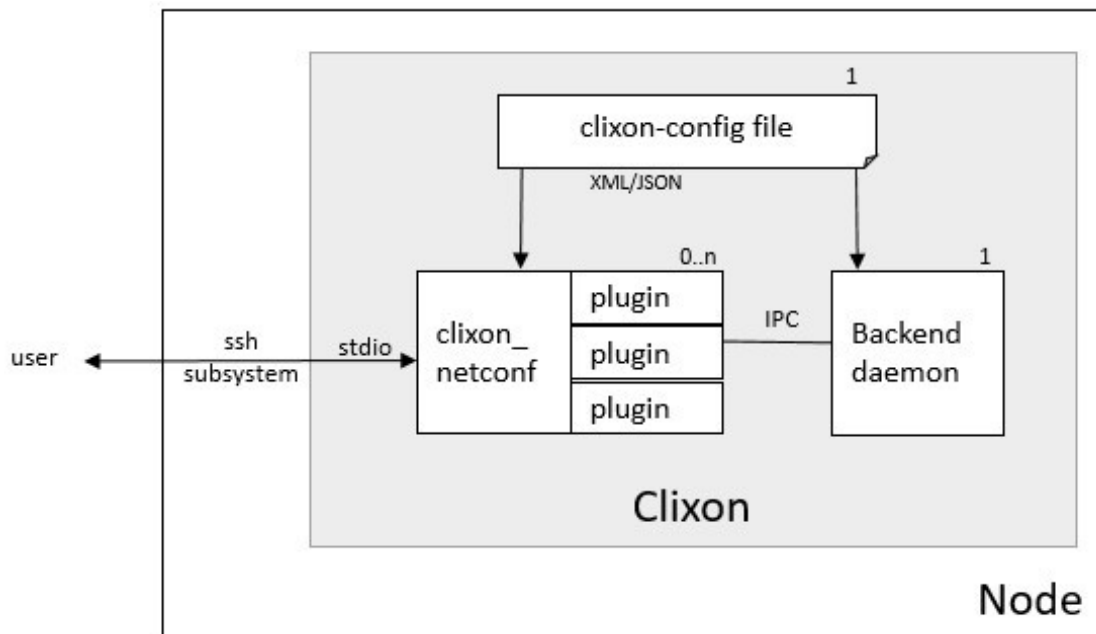

Netconf is defined in RFC 6241 (see *Standards section*) and implemented by the *clixon_netconf* client.

Any number of netconf clients can be created, each creating a new session to the backend. The netconf client communicates to the outside world via *stdio*. Usually one sets up an SSH sub-system to communicate from external nodes.

Note that Netconf supports chunked framing defined in RFC 6241 from Clixon 5.7, but examples may not be updated.

10.1.1 10.1.1 Command-line options

The *clixon_netconf* client has the following command-line options:

-h	Help
-V	Show version and exit
-D <level>	Debug level
-f <file>	Clixon config file
-E <dir>	Extra configuration directory
-l <option>	Log on (s)yslog, std(e)rr, std(o)ut or (f)ile. Syslog is default. If foreground, then syslog and stderr is default.
-C <format>	Dump configuration options on stdout after loading and quit. Format is one of xml json text
-q	Quiet mode, server does not send hello message on startup
-0	Set netconf base capability to 0, server does not expect hello, force EOM framing
-1	Set netconf base capability to 1, server does not expect hello, force chunked framing
-a <family>	Internal IPC backend socket family: UNIX IPv4 IPv6
-u <path addr>	Internal IPC socket domain path or IP addr (see -a)
-d <dir>	Specify netconf plugin directory
-p <dir>	Add Yang directory path (see CLICON_YANG_DIR)
-y <file>	Load yang spec file (override yang main module)
-U <user>	Over-ride unix user with a pseudo user for NACM.
-t <sec>	Timeout in seconds. Quit after this time.
-e	Do not ignore errors on packet input.
-o <option=value>	Give configuration option overriding config file (see clixon-config.yang)

10.1.2 10.1.2 Configure options

The configuration file options related to NETCONF are the following:

CLICON_NETCONF_DIR

Location of netconf .so plugins loaded alphabetically

CLICON_NETCONF_HELLO_OPTIONAL

If true, an RPC can be processed directly with no preceding hello message. This is not according to the standard RFC 6241 Sec 8.1.

CLICON_NETCONF_MESSAGE_ID_OPTIONAL

If true, an RPC can be sent without a message-id. This is not according to the standard RFC 6241 Sec 4.1.

10.2 10.2 Starting

The Netconf client (`clixon_netconf`) can be started on the command line using stdin/stdout:

```
> clixon_netconf -qf /usr/local/etc/clixon.conf < my.xml
```

It then reads and parses Netconf commands on stdin, eventually invokes Netconf plugin callbacks, then establishes a connection to the backend and usually sends the Netconf message over IPC to the backend. Some commands (eg hello) are terminated in the client. The reply from the backend is then displayed on stdout.

10.2.1 10.2.1 SSH subsystem

You can expose `clixon_netconf` as an SSH subsystem according to *RFC 6242*. Register the subsystem in `/etc/sshd_config`:

```
Subsystem netconf /usr/local/bin/clixon_netconf

# Add the dedicated NETCONF port
Port 830

# Force NETCONF subsystem on port 830
Match LocalPort 830
    ForceCommand /usr/local/bin/clixon_netconf -f /usr/local/etc/clixon.xml
```

The netconf Subsystem is listening at port 830(default port for NETCONF over SSH is 830) and now invoke it from a client using:

```
ssh -s <host> -p 830 netconf
```

10.3 10.3 NACM

Clixon implements the [Network Configuration Access Control Model](#) (NACM / RFC8341). NACM rpc and datanode access validation is supported, not outgoing notifications.

NACM rules apply to all datastores.

10.3.1 10.3.1 Restrictions

Access notification authorization (Sec 3.4.6) is NOT implemented.

Data-node paths, eg `<rule>...<path>ex:table/ex:parameter</path></rule>` instance-identifiers are restricted to canonical namespace identifiers for both XML and JSON encoding. That is, if a symbol (such as `table` above) is a symbol in a module with prefix `ex`, another prefix cannot be used, even though defined with a `xmlns` rule.

The `enable-external-groups` switch is not implemented.

10.3.2 10.3.2 Config options

The following configuration options are related to NACM:

CLICON_NACM_MODE

NACM mode is either: *disabled*, *internal*, or *external*. Default: *disabled*.

CLICON_NACM_FILE

If NACM mode is external, this file contains the NACM config.

CLICON_NACM_CREDENTIALS

Verify NACM user credentials with unix socket peer credentials. This means that a NACM user must match a UNIX user accessing CLIXON_SOCKET. Credentials are either: *none*, *exact* or *except*. Default: *except*.

CLICON_NACM_RECOVERY_USER

RFC8341 defines a ‘recovery session’ as outside its scope. Clixon defines this user as having special admin rights to exempt from all access control enforcements.

CLICON_NACM_DISABLED_ON_EMPTY

RFC 8341 defines enable-nacm as true by default. Since also write-default is deny by default it leads to that empty configs can not be edited. Default: *false*.

10.3.3 10.3.3 Mode

NACM rules are either internal or external. If external, rules are loaded from a separate file, specified by the option CLICON_NACM_FILE.

If the NACM mode is internal, the NACM configuration is a part of the regular candidate/running datastore. NACM rules are read from the *running* datastore, ie they need to be committed.

Since NACM rules are part of the config itself it means that there may be bootstrapping issues. In particular, NACM default is *enabled* with read/exec permit, and write *deny*. Loading an empty config therefore leads to a “deadlock” where no user can edit the datastore.

Work-arounds include restarting the backend with a NACM config in the startup db, or using a *recovery user*.

10.3.4 10.3.4 Access control

NACM is implemented in the Clixon backend at:

- Incoming RPC (module-name/protocol-operation)
- Before modifying the data store (data create/delete/update)
- After retrieving data (data read)

User credentials

Access control relies on a user and groups. When an internal Clixon client communicates with the backend, it piggy-backs the name of the user in the request, See *Internal netconf username*:

```
<rpc username="myuser"><get-config><source><running/></source></get-config></rpc>
```

The authentication of the username needs to be done in the client by either SSL certs (such as in *RESTCONF auth callback*) or by SSH (as in *NETCONF/CLI over SSH*).

The Clixon backend can check credentials of the client if it uses a UNIX socket (not IP socket) for internal communication between clients and backend. In this way, a username claimed by a client can be verified against the UNIX user credentials.

The allowed values of `CLICON_NACM_CREDENTIALS` is:

- *none*: Do not match NACM user to any user credentials. Any user can pose as any other user. Set this for IP sockets, or do not use NACM.
- *exact*: Exact match between NACM user and unix socket peer user.
- *except*: Exact match between NACM user and unix socket peer user, *except* for root and *wwwuser*. This is default.

10.3.5 10.3.5 Recovery user

RFC 8341 defines a NACM emergency recovery session mechanism. Clixon implements a recovery user set by option `CLICON_NACM_RECOVERY_USER`. If a client accesses the backend as that user, all NACM rules will be bypassed. By default there is no such user.

Moreover, this mechanism is controlled by *user credentials* which means you can control who can act as the recovery user.

For example, by setting `CLICON_NACM_CREDENTIALS` to *except* the RESTCONF daemon can make backend calls posing as the recovery user, even though it runs as *wwwuser*.

Alternatively, `CLICON_NACM_CREDENTIALS` can be set to *exact* and the recovery user as *root*, in which case only a netconf or cli session running as root can make recovery operations.

10.4 10.4 Confirm-commit

Confirm as defined in RFC 6241 Sec 8.4 is enabled by:

```
<CLICON_FEATURE>ietf-netconf:confirmed-commit</CLICON_FEATURE>
```

Confirmed-commit adds the `<cancel-commit>` operation and more parameters to `<commit>`.

The “rollback” datastore is added and is used as a temporary revert datastore.

10.5 10.5 Callhome

With Clixon, you can make a solution following [RFC 8071: NETCONF Call Home and RESTCONF Call Home](#) over SSH as a utility using openssh.

The solution is built “around” Clixon meaning that Clixon itself is used as-is. This may be referred to as “external” callhome since it is done using external tools, not clixon itself. In contrast, rstconf call-home is “internal”, see callhome section in *Restconf section*.

Other solutions are possible as well, especially on the client side, and a full system integration requires a callhome framework to determine when and how callhomes are made as well as addressing the security implications addressed by RFC 8071.

Overview of a callhome architecture with a device (where clixon resides) and a client:

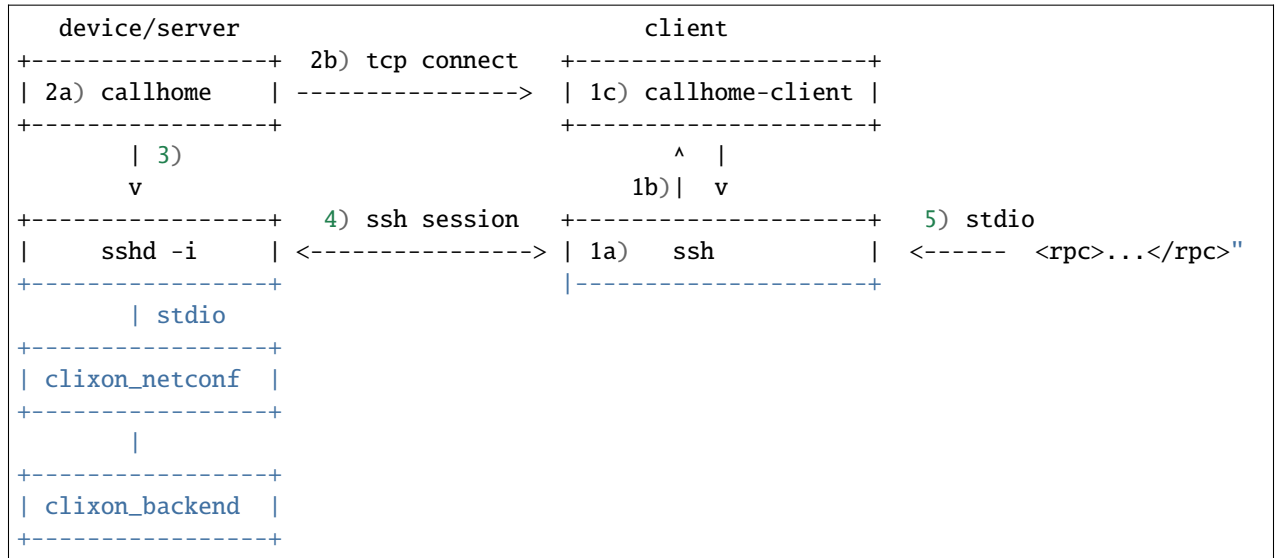

Requirement for the netconf callhome solutions are openssh and openssh-server.

The steps to make a Netconf callhome is as follows:

- 1) Start the ssh client using `-o ProxyUseFdpass=yes -o ProxyCommand="callhome-client"`. Callhome-client listens on port 4334 for incoming TCP connections.
- 2) Start the callhome program on the server making tcp connect to client on port 4334 establishing a tcp stream with the client
- 3) The callhome program starts `sshd -i` using the established stream socket
- 4) The callhome-client returns with an open stream socket to the ssh client establishing an SSH stream to the server
- 5) Netconf messages are sent on stdin to the ssh client in turn using the established SSH stream and the Netconf subsystem to clixon, which returns a reply.

The callhome and callhome-client referred to above are implemented by the utility functions: `clixon_netconf_ssh_callhome` and `clixon_netconf_ssh_callhome_client` found in [clixon utilities](#)

Example:

```
# Start ssh on client: bind to 1.2.3.4:4334 sending an rpc on stdin
client> echo '<?xml version="1.0" encoding="UTF-8"?><hello xmlns=
↳"urn:ietf:params:xml:ns:netconf:base:1.0"><capabilities><capability>
↳urn:ietf:params:netconf:base:1.1</capability></capabilities></hello>]]><rpc xmlns=
↳"urn:ietf:params:xml:ns:netconf:base:1.0"><get-config><source><candidate/></source></
↳get-config></rpc>]]>>' > msg
client> ssh -s -v -o ProxyUseFdpass=yes -o ProxyCommand="clixon_netconf_ssh_callhome_
↳client -a 1.2.3.4" . netconf < msg

# Start callhome on server: connect to 1.2.3.4:4334
server> sudo clixon_netconf_ssh_callhome -a 1.2.3.4

# Reply on client stdout: (skipping hello):
<rpc-reply xmlns="urn:ietf:params:xml:ns:netconf:base:1.0"><data/></rpc-reply>]]>>
```

The example is implemented as a regression test in `test/test_netconf_ssh_callhome.sh`

The RFC lists several security issues that need to be addressed in a solution, including “pinning” of host keys etc.

Note: Warning: there are security implications of using this example as noted in [RFC 8071: NETCONF Call Home and RESTCONF Call Home](#)

10.6 10.6 Internal NETCONF

Clixon uses NETCONF in the internal IPC protocol between its clients (cli/netconf/restconf) and the backend. This *internal* Netconf (IPC) is slightly different from regular Netconf:

- Fixed to Netconf 1.1 framing
- Default runs over a Unix socket
- No hello / capability exchange
- Netconf extentions

Note: The IPC is an internal interface, do not use externally

10.6.1 10.6.1 Extensions

The internal IPC protocol have a couple of attributes that are extensions to the Netconf protocol. These attributes are all in the `clixon-lib` namespace (<http://clixon.org/lib>)

- *content* - for `get` command with values “config”, “nonconfig” or “all”, to indicate which parts of state and config are requested. This option is taken from RESTCONF. Example:

```
<rpc xmlns="urn:ietf:params:xml:ns:netconf:base:1.0">
  <get cl:content="nonconfig" xmlns:cl="http://clixon.org/lib"/>
</rpc>
```

- *depth* - for `get` and `get-config` how deep a tree is requested. Also from RESTCONF. Example:

```
<rpc xmlns="urn:ietf:params:xml:ns:netconf:base:1.0">
  <get cl:depth="2" xmlns:cl="http://clixon.org/lib"/>
</rpc>
```

- *username* - for top-level `rpc` command. Indicates which user the client represents (“pseudo-user”). This is either the actual user logged in as the client (eg “peer-user”) or can represent another user. The credentials mode determines the trust-level of the pseudo-username. Example:

```
<rpc username="root" xmlns:cl="http://clixon.org/lib" xmlns=
->"urn:ietf:params:xml:ns:netconf:base:1.0">
  <close-session/>
</rpc>
```

- *autocommit* - for `edit-config`. If true, perform a `commit` operation immediately after an edit. If this fails, make a `discard` operation. Example:

```
<rpc xmlns="urn:ietf:params:xml:ns:netconf:base:1.0">
  <edit-config cl:autocommit="true" xmlns:cl="http://clixon.org/lib">
```

(continues on next page)

(continued from previous page)

```

    <target><candidate/></target>
    <config>...</config>
  </edit-config>
</rpc>

```

- *copystartup* - for *edit-config* combined with *autocommit*. If true, copy the running db to the startup db after a commit. The combination with *autocommit* is the default for RESTCONF operations. Example:

```

<rpc xmlns="urn:ietf:params:xml:ns:netconf:base:1.0">
  <edit-config cl:autocommit="true" cl:copystartup="true" xmlns:cl="http://clixon.
  ↪org/lib">
    <target><candidate/></target>
    <config>...</config>
  </edit-config>
</rpc>

```

- *transport* - for hello from RFC 6022. Example:

```

<hello cl:transport="netconf" xmlns:cl="http://clixon.org/lib" xmlns=
  ↪"urn:ietf:params:xml:ns:netconf:base:1.0" >

```

- *source-host* - for hello from RFC 6022. Example:

```

<hello cl:source-host="10.10.0.42" xmlns:cl="http://clixon.org/lib" xmlns=
  ↪"urn:ietf:params:xml:ns:netconf:base:1.0" >

```

- *objectcreate* and *objectexisted* - in the data field of *edit-config* XML data tree. In the request set *objectcreate* to false/true whether an object should be created if it does not exist or not. If such a request exists, then the ok reply should contain “objectexists” to indicate whether the object existed or not (eg prior to the operation). The reason for this protocol is to implement some RESTCONF PATCH and PUT functionalities. Example:

```

<rpc xmlns="urn:ietf:params:xml:ns:netconf:base:1.0">
  <edit-config objectcreate="false"><target><candidate/></target>
  <config>
    <protocol objectcreate="true">tcp</protocol>
  </config>
</edit-config>
</rpc>]]>]]>
<rpc-reply xmlns="urn:ietf:params:xml:ns:netconf:base:1.0">
  <ok objectexisted="true"/>
</rpc-reply>]]>]]>

```

The reason for introducing the *objectcreate/objectexisted* attributes are as follows:

- RFC 8040 4.5 PUT: if the PUT request creates a new resource, a “201 Created” status-line is returned. If an existing resource is modified, a “204 No Content” status-line is returned.
- RFC 8040 4.6 PATCH: If the target resource instance does not exist, the server MUST NOT create it.

11 RESTCONF

Clixon supports two RESTCONF compile-time variants: *FCGI* and *Native*.

11.1 11.1 Architecture

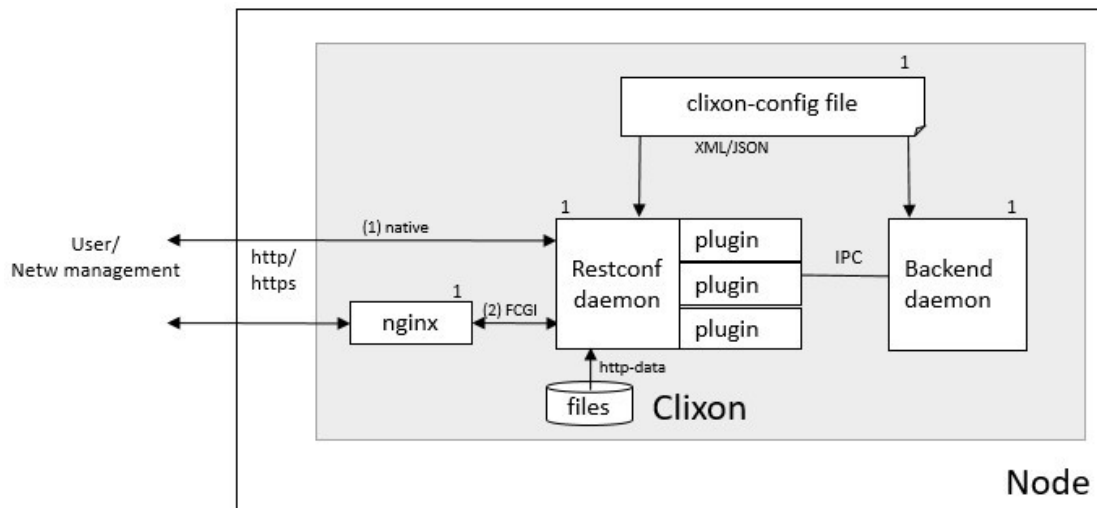

The restconf daemon provides a http/https RESTCONF interface to the Clixon backend. It comes in two variants, as shown in the figure above:

1. Native http, which combines a HTTP and Restconf server. Further, HTTP configuration is made using Clixon.
2. A reverse proxy (such as NGINX) and FastCGI where web and restconf function is separated. NGINX is used to make all HTTP configuration.

The restconf daemon communicates with the backend using internal netconf over the CLIXON_SOCKET. If FCGI is used, there is also a FCGI socket specified by `fcgi-socket` in `clixon-config/restconf`.

The restconf daemon reads its initial config options from the configuration file on startup. The native http variant can read config options from the backend as an alternative to reading everything from clixon options.

You can add plugins to the restconf daemon, where the primary usecase is authentication, using the `ca_auth` callback.

Note that there is some complexity in the configuration of the different variants of native Clixon restconf involving HTTP/1 vs HTTP/2, TLS vs plain HTTP, client cert vs basic authentication and external vs internal daemon start.

Further, ALPN is used to select http/1 or http/2 in HTTPS.

11.2 11.2 Installation

The RESTCONF daemon can be configured for compile-time (by autotools) as follows:

- disable-http1** Disable native http/1.1 (ie http/2 only)
- disable-nhttp2** Disable native http/2 using libnhttp2 (ie http/1 only)
- with-restconf=native** RESTCONF using native http. (DEFAULT)
- with-restconf=fcgi** RESTCONF using fcgi/ reverse proxy.
- without-restconf** No RESTCONF

After that perform system-wide compilation:

```
make && sudo make install
```

11.3 11.3 Command-line options

The restconf daemon have the following command-line options:

- h** Help
- V** Show version and exit
- D <level>** Debug level
- f <file>** Clixon config file
- E <dir>** Extra configuration directory
- l <option>** Log on (s)yslog, std(e)rr, std(o)ut, (n)one or (f)ile. Syslog is default. If foreground, then syslog and stderr is default.
- C <format>** Dump configuration options on stdout after loading and quit. Format is one of xml|json|text
- p <dir>** Add Yang directory path (see CLICON_YANG_DIR)
- y <file>** Load yang spec file (override yang main module)
- a <family>** Internal backend socket family: UNIX|IPv4|IPv6
- u <path|addr>** Internal socket domain path or IP addr (see -a)
- r** Do not drop privileges if run as root
- W <user>** Run restconf daemon as this user, drop according to CLICON_RESTCONF_PRIVILEGES
- R <xml>** Restconf configuration in-line overriding config file
- t <sec>** Upper bound on notification event streams (native debugging)
- o <option=value>** Give configuration option overriding config file (see clixon-config.yang)

Note that the restconf daemon started as root, drops privileges to *wwwuser*, unless the **-r** command-line option is used, or CLICON_RESTCONF_PRIVILEGES is defined.

11.4 11.4 Configuration options

The following RESTCONF configuration options can be defined in the clixon configuration file:

CLICON_RESTCONF_DIR

Location of restconf .so plugins. Load all .so plugins in this dir as restconf code plugins.

CLICON_RESTCONF_INSTALLDIR

Path to dir of clixon-restconf daemon binary as used by backend if started internally

CLICON_RESTCONF_STARTUP_DONTUPDATE

Disable automatic update of startup on restconf edit operations This is not according to standard RFC 8040 Sec 1.4.

CLICON_RESTCONF_USER

Run clixon_restconf daemon as this user, default is *www-data*.

CLICON_RESTCONF_PRIVILEGES

Restconf daemon drop privileges mode, one of: none, drop_perm, drop_temp

CLICON_RESTCONF_HTTP2_PLAIN

Enable plain (non-tls) HTTP/2.

CLICON_BACKEND_RESTCONF_PROCESS

Start restconf daemon internally from backend daemon. The restconf daemon reads its config from the backend running datastore.

CLICON_ANONYMOUS_USER

If RESTCONF authentication auth-type=none then use this user

CLICON_RESTCONF_API_ROOT

RESTCONF API root path as defined in RFC 8040, default is */restconf*

CLICON_NOALPN_DEFAULT

Fallback if no ALPN for https. valid values are "http/1.1" and "http/2"

More more documentation of the options, see the source YANG file.

11.5 11.5 Advanced config

Apart from options, there is also structured restconf data primarily for native mode encapsulated with `<restconf>..</restconf>` as defined in `clixon-restconf.yang`.

The first-level fields of the advanced restconf structure are the following:

enable

Enable the RESTCONF daemon. If disabled, the restconf daemon will not start

auth-type

Authentication method (see *auth types*)

debug

Set debug level, must be decimal

log-destination

Either syslog or file (`/var/log/clixon_restconf.log`)

pretty

Restconf values are pretty printed by default. Disable to turn this off

The advanced config can be given using three different methods

1. inline - as command-line option using -R
2. config-file - as part of the regular config file
3. datastore - committed in the regular running datastore

11.5.1 11.5.1 Inline

When starting the restconf daemon, structured data can be directly given as a command-line option:

```
-R <restconf xmlns="http://clixon.org/restconf"><enable>true</enable></restconf>
```

11.5.2 11.5.2 Config file

The restconf config can also be defined locally within the clixon config file, such as:

```
<CLICON_FEATURE>clixon-restconf:fcgi</CLICON_FEATURE>
<CLICON_BACKEND_RESTCONF_PROCESS>true</CLICON_BACKEND_RESTCONF_PROCESS>
<restconf>
  <enable>true</enable>
  <fcgi-socket>/wwwdata/restconf.sock</fcgi-socket>
</restconf>
```

Additionally, The <restconf>... can be in a separate file using the -E configuration directory option.

11.5.3 11.5.3 Datastore

Finally, if CLICON_BACKEND_RESTCONF_PROCESS is set, restconf is configuration is in the datastore, not configuration file.

The detailed restconf is defined in the regular running datastore by importing clixon-restconf.yang into your top-level yang:

```
import clixon-restconf {
  prefix clrc; /* This pulls in top-level clrc:restconf */
}
```

Then, the restconf configuration can be part of the datastore:

```
<restconf xmlns="http://clixon.org/restconf">
  <enable>true</enable>
  <fcgi-socket>/wwwdata/restconf.sock</fcgi-socket>
</restconf>
```

In the latter case, the restconf daemon reads its config from the running datastore on startup.

Having the restconf configuration in the datastore is more dynamic and flexible, but the bootstrapping is more complex.

Note: If CLICON_BACKEND_RESTCONF_PROCESS is enabled, the restconf config is in the regular datastore.

11.5.4 11.5.4 Features

The Restconf config has two features:

fcgi

The restconf server supports the fast-cgi reverse proxy mode. Set this if fcgi/nginx is used.

allow-auth-none

Authentication supports a *none* mode.

Example, add this in the config file to enable fcgi:

```
<clixon-config xmlns="http://clixon.org/config">
  ...
  <CLICON_FEATURE>clixon-restconf:fcgi</CLICON_FEATURE>
```

11.5.5 11.5.5 Auth types

The RESTCONF daemon uses the following authentication types:

none

Messages are not authenticated and set to the value of CLICON_ANONYMOUS_USER. A callback can revise this behavior. Note, must set *allow-auth-none* feature.

client-cert

Set to authenticated and extract the username from the SSL_CN parameter. A callback can revise this behavior.

user

User-defined behaviour as implemented by the *auth callback*. Typically done by basic auth, eg HTTP_AUTHORIZATION header, and verify password

11.5.6 11.5.6 FCGI mode

Applies if clixon is configured with `--with-restconf=fcgi`. Fcgi-specific config options are:

fcgi-socket

Path to FCGI unix socket. This path should be the same as specific in fcgi reverse proxy

Need also fcgi feature enabled: *features*

11.5.7 11.5.7 Native mode

Applies if clixon is configured with `--with-restconf=native`. Native specific config options are:

server-cert-path

Path to server certificate file

server-key-path

Path to server key file

server-ca-cert-path

Path to server CA cert file

socket

List of server sockets that the restconf daemon listens to with the following fields:

socket namespace

Network namespace

socket address

IP address to bind to

socket port

TCP port to bind to

socket ssl

If true: HTTPS; if false: HTTP protocol

11.5.8 11.5.8 Examples

Configure a single HTTP on port 80 in the default config file:

```
<clixon-config xmlns="http://clixon.org/config">
  <CLICON_CONFIGFILE>/usr/local/etc/clixon.xml</CLICON_CONFIGFILE>
  ...
  <restconf>
    <enable>true</enable>
    <auth-type>user</auth-type>
    <socket>
      <description>HTTP listen</description>
      <namespace>default</namespace>
      <address>0.0.0.0</address>
      <port>80</port>
      <ssl>>false</ssl>
    </socket>
  </restconf>
</clixon-config>
```

Configure two HTTPS listeners in two different namespaces:

```
<restconf xmlns="https://clixon.org/restconf">
  <enable>true</enable>
  <auth-type>client-certificate</auth-type>
  <server-cert-path>/etc/ssl/certs/clixon-server.crt.pem</server-cert-path>
  <server-key-path>/etc/ssl/private/clixon-server-key.pem</server-key-path>
  <server-ca-cert-path>/etc/ssl/certs/clixon-ca.crt.pem</server-ca-cert-path>
  <socket>
    <description>HTTPS listen</description>
    <namespace>default</namespace>
    <address>0.0.0.0</address>
    <port>443</port>
    <ssl>true</ssl>
  </socket>
  <socket>
    <description>HTTPS listen on myns</description>
    <namespace>myns</namespace>
    <address>0.0.0.0</address>
    <port>443</port>
    <ssl>true</ssl>
  </socket>
</restconf>
```

11.5.9 11.5.9 SSL Certificates

If you use native RESTCONF you may want to have server/client certs. If you use FCGLI, certs are configured according to the reverse proxy documentation, such as NGINX. The rest of this section applies to native restconf only.

If you already have certified server certs, ensure CLICON_SSL_SERVER_CERT and CLICON_SSL_SERVER_KEY points to them.

If you do not have them, you can generate self-signed certs, for example as follows:

```
openssl req -x509 -nodes -newkey rsa:4096 -keyout /etc/ssl/private/clixon-server-key.pem
↪-out /etc/ssl/certs/clixon-server-crt.pem -days 365
```

You can also generate client certs (not shown here) using CLICON_SSL_CA_CERT. Example using client certs and curl for client *andy*:

```
curl -Ssik --key andy.key --cert andy.crt -X GET https://localhost/restconf/data/
↪example:x
```

11.6 11.6 Starting

You can start the RESTCONF daemon in several ways:

1. *systemd* , externally started
2. *internally* using the *process-control* RPC (see below)
3. *docker* mechanisms, see the docker container docs

11.6.1 11.6.1 Start with Systemd

The Restconf service can be installed at, for example, `/etc/systemd/system/example_restconf.service`:

```
[Unit]
Description=Starts and stops an example clixon restconf service on this system
Wants=example.service
After=example.service
[Service]
Type=simple
User=root
Restart=on-failure
ExecStart=/usr/local/sbin/clixon_restconf -f /usr/local/etc/clixon/example.xml
[Install]
WantedBy=multi-user.target
```

11.6.2 11.6.2 Internal start

For starting restconf internally, you need to enable CLICON_BACKEND_RESTCONF_PROCESS option. See Section *data-store*.

Thereafter, you can either use the `clixon-restconf.yang` configuration or use the `clixon-lib.yang` process control RPC:s to start/stop/restart the daemon or query status.

The algorithm for starting and stopping the `clixon-restconf` internally is as follows:

1. on RPC start, if enable is true, start the service, if false, error or ignore it
2. on RPC stop, stop the service
3. on backend start make the state as configured
4. on enable change, make the state as configured

Example 1, using netconf *edit-config* to start the process:

```
<?xml version="1.0" encoding="UTF-8"?>
<hello xmlns="urn:ietf:params:xml:ns:netconf:base:1.0">
  <capabilities><capability>urn:ietf:params:netconf:base:1.1</capability></capabilities>
</hello>]]>]]>
<rpc xmlns="urn:ietf:params:xml:ns:netconf:base:1.0" message-id="10">
  <edit-config>
    <default-operation>merge</default-operation>
    <target><candidate/></target>
    <config>
      <restconf xmlns="http://clixon.org/restconf">
        <enable>true</enable>
      </restconf>
    </config>
  </edit-config>
</rpc>
<rpc-reply xmlns="urn:ietf:params:xml:ns:netconf:base:1.0" message-id="10">
  <ok/>
</rpc-reply>
<rpc xmlns="urn:ietf:params:xml:ns:netconf:base:1.0" message-id="11">
  <commit/>
</rpc>
<rpc-reply xmlns="urn:ietf:params:xml:ns:netconf:base:1.0" message-id="10">
  <ok/>
</rpc-reply>
```

Example 2, using netconf RPC to restart the process:

```
<?xml version="1.0" encoding="UTF-8"?>
<hello xmlns="urn:ietf:params:xml:ns:netconf:base:1.0">
  <capabilities><capability>urn:ietf:params:netconf:base:1.1</capability></capabilities>
</hello>]]>]]>
<rpc xmlns="urn:ietf:params:xml:ns:netconf:base:1.0" message-id="10">
  <process-control xmlns="http://clixon.org/lib">
    <name>restconf</name>
    <operation>restart</operation>
  </process-control>
</rpc>
```

(continues on next page)

(continued from previous page)

```
<rpc-reply xmlns="urn:ietf:params:xml:ns:netconf:base:1.0" message-id="10">
  <pid xmlns="http://clixon.org/lib">1029</pid>
</rpc-reply>
```

Note that the backend daemon must run as root (no lowering of privileges) to use this feature.

11.7 11.7 Plugin callbacks

Restconf plugins implement callbacks, some are same as for *backend plugins*.

init

Clixon plugin init function, called immediately after plugin is loaded into the restconf daemon.

start

Called when application is started and initialization is complete, and after drop privileges.

exit

Called just before plugin is unloaded

extension

Called at parsing of yang modules containing an extension statement.

auth

See *auth callback*

11.7.1 11.7.1 Auth callback

The role of the authentication callback is, given a message (its headers) and authentication type, determine if the message passes authentication and return an associated user.

The auth callback is invoked after incoming processing, including cert validation, if any, but before relaying the message to the backend for NACM checks and datastore processing.

If the message is not authenticated, an error message is returned with tag: *access denied* and HTTP error code *401 Unauthorized*.

There are default handlers for TLS client certs and for “none” authentication. But other variants, such as http basic authentication, oauth2 or the remapping of client certs to NACM usernames, can be implemented by this callback

If the message is authenticated, a user is associated with the message. This user can be derived from the headers or mapped in an application-dependent way. This user is used internally in Clixon and sent via the IPC protocol to the backend where it may be used for NACM authorization.

The signature of the auth callback is as follows:

```
int ca_auth(clixon_handle h, void *req, clixon_auth_type_t auth_type, char **authp);
```

where:

h

Clixon handle

req

Per-message request www handle to use with restconf_api.h

auth-type

Specifies how the authentication is made and what default value

authp

NULL if credentials failed, otherwise malloced string of authenticated user

The return value is one of:

- -1: Fatal error, close socket
- 0: Ignore, undecided, not handled, same as no callback. Fallback to default handler.
- 1: OK see authp parameter whether the result is authenticated or not, and the associated user.

If there are multiple callbacks, the first result which is not “ignore” is returned. This is to allow for different callbacks registering different classes, or grouping of authentication.

The main example contains example code.

11.8 11.8 FCGI

This section describes the RESTCONF FCGI mode using NGINX.

You need to configure the following:

1. Configure clixon with `--with-restconf=fcgi`
2. Restconf config in the Clixon config file
3. Reverse proxy configuration
4. Start the restconf daemon (see *starting*)

11.8.1 11.8.1 Restconf config

The restconf daemon can be started in several ways as described in Section *auth types*. In all cases however, the configuration is simpler than in native mode. For example:

```
<clixon-config xmlns="http://clixon.org/config">
  ...
  <CLICON_FEATURE>clixon-restconf:fcgi</CLICON_FEATURE>
  <restconf>
    <enable>true</enable>
    <fcgi-socket>/wwwdata/restconf.sock</fcgi-socket>
  </restconf>
</clixon-config>
```

11.8.2 11.8.2 Reverse proxy config

If you use FCGI, you need to configure a reverse-proxy, such as NGINX. A typical configuration is as follows:

```
server {
  ...
  location / {
    fastcgi_pass unix:/www-data/fastcgi_restconf.sock;
    include fastcgi_params;
  }
}
```

where `fastcgi_pass` setting should match by `fcgi-socket` in `clixon-config/restconf`.

11.9 11.9 Callhome

Clixon supports RESTCONF callhome according to [RFC 8071: NETCONF Call Home and RESTCONF Call Home](#) using native RESTCONF and TLS and server/client certs.

11.9.1 11.9.1 Overview

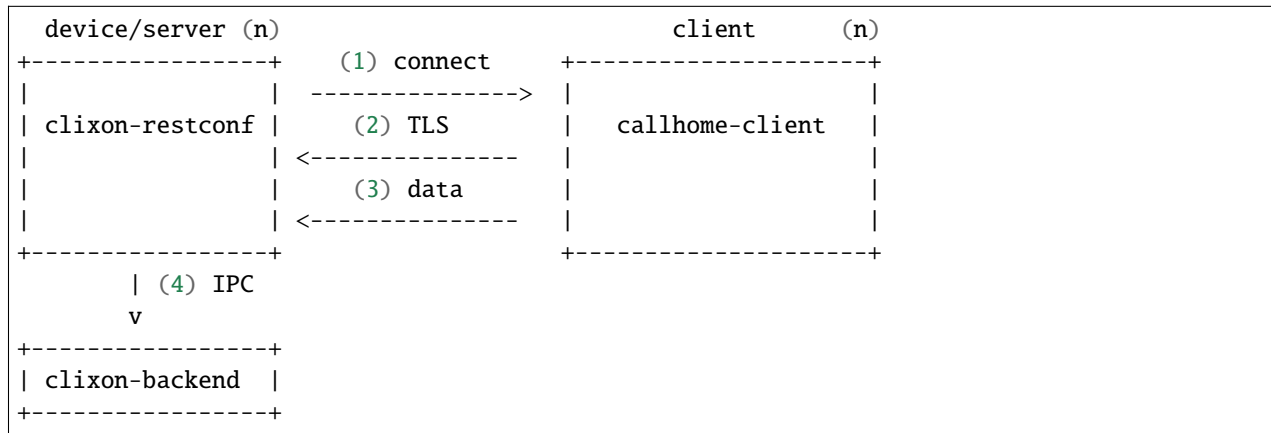

The operation of RESTCONF callhome is as follows:

1. The RESTCONF server initiates a TCP connection to a client, either persistently or periodically
2. The client sets up a TLS connection to the server using the existing TCP session
3. The client sends data as HTTP requests over TLS to the server
4. The RESTCONF server receives data, authenticates the client-cert, transforms the request to NETCONF and sends it internally to the clixon backend.
5. Status replies are returned to the client

Note: Clixon does not implement client-side call-home functionality, only server-side

11.9.2 11.9.2 Callback clients

A server may configure multiple HTTP callback clients, for fault-tolerance purposes, for example.

A callback “controller” client typically serves multiple servers.

Bootstrap controller

A typical callback client scenario is a bootstrap controller. The HTTP requests by the client are stored waiting for an initial connect from a minimally deployed server. The controller may then store pre-configured configurations. In such a scenario, the server needs at least the following initial information:

1. A callback IP address
2. A server cert
3. A CA to validate the client cert OR a list of exactly matching client-certs

Once the controller accepts a connection from a server, it may send RESTCONF requests over HTTP and fully configure the new server.

Such a controller can also be used for more “intelligent” configuration as well, such as setting up tunnels or other configurations spanning multiple servers.

The controller may also provide an interactive CLI or GUI for example once a connection is established.

11.9.3 11.9.3 Description

The callhome function is “internal” in the sense that it is integrated in Clixon and uses the openssl lib and extends the regular “listen” RESTCONF functionality.

The callhome mechanism is a server-side implementation. There is an example client-side implementation (*util/clixon_restconf_callhome_client.c*) which is not a part of the actual Clixon code. A user needs to write a client to use this functionality.

The existing clixon-restconf YANG has been extended to support callhome. The ietf restconf server draft (<https://datatracker.ietf.org/doc/html/draft-ietf-netconf-restconf-client-server-26>) which is used as a basis for the extensions. While not complying to the draft’s structure, the YANG fields covering callhome are similar. Please see the draft for detailed description of scenarios and configuration fields.

The callhome features include:

- *Persistent* and *periodic* connection types, ie continuous callhome attempts, or at specific time intervals.
- Periodic connections support *idle-timeout*, ie close the TCP connection if no traffic after timeout.
- *Max-attempts* reconnect strategy, ie how many times to retry a connect attempt before timeout

11.9.4 11.9.4 Setup

A callhome session is setup by adding a `call-home` section to a native RESTCONF socket declaration. For example:

```
<restconf xmlns="https://clixon.org/restconf">
  <enable>true</enable>
  <auth-type>client-certificate</auth-type>
  <server-cert-path>/etc/ssl/certs/clixon-server-crt.pem</server-cert-path>
  <server-key-path>/etc/ssl/private/clixon-server-key.pem</server-key-path>
  <server-ca-cert-path>/etc/ssl/certs/clixon-ca.crt.pem</server-ca-cert-path>
  <socket>
    <description>callhome session</description>
    <namespace>default</namespace>
    <address>12.13.14.15</address>
    <port>4336</port>
    <ssl>true</ssl>
  </socket>
</restconf>
```

(continues on next page)

(continued from previous page)

```

<call-home>
  <!-- ... call-home section ... -->
</call-home>
</socket>

```

Some notes for callhome sockets:

1. The `address` field denotes a remote client, not the server which is the case for “listen” sockets.
2. The default `port` for RESTCONF callhome is `4336`
3. A callhome socket must have `ssl` enabled
4. Client certs must be used as `auth-type`
5. You can mix regular “listen” sockets with “callhome” sockets.
6. You can have multiple (concurrent) callhome sockets.

11.9.5 11.9.5 Persistent connection

If the callhome session is persistent, the server tries to hold the connection open at all times. The default re-connect strategy is 1 second.

Example socket configuration:

```

<call-home>
  <connection-type>
    <persistent/>
  </connection-type>
</call-home>

```

11.9.6 11.9.6 Periodic connection

Periodic call-home sessions try to establish a callhome connections at regular intervals, such as once a minute, or once a day.

Example periodic configuration:

```

<call-home>
  <connection-type>
    <periodic>
      <period>3600</period>
      <idle-timeout>60</idle-timeout>
    </periodic>
  </connection-type>
  <reconnect-strategy>
    <max-attempts>3</max-attempts>
  </reconnect-strategy>
</call-home>

```

Notes:

1. The *period* is in seconds, while the draft uses minutes. The example therefore shows a period of one hour.
2. The *idle-timeout* field means that the TCP session is closed by the server if no data is sent in 1 minute.

3. The *max-attempts* setting means that every start of period the server makes several attempts to reconnect. If all attempts fail, it waits another period before re-trying.
4. If the connection is active when the new period starts, no reconnect attempt is made.

11.10 HTTP data

As an extension to the native restconf implementation, Clixon provides a limited http-data server for displaying web pages. To use the http-data feature, you need to configure clixon with `--with-restconf=native` and also enable the http-data feature as described below.

Note: The http data feature is limited and can only be used for very simple web content

11.10.1 Configuration options

First, you also need to define `<CLICON_FEATURE>clixon-restconf:http-data</CLICON_FEATURE>` to enable http-data.

The following configuration options can be defined in the clixon configuration file:

CLICON_HTTP_DATA_ROOT

Directory in the local file system where http-data files are searched for. Soft links, `..`, `~` etc are not followed. Default is `/var/www`.

CLICON_HTTP_DATA_PATH

Prefix to match with URI to match for http-data. This path is appended to `CLICON_HTTP_DATA_ROOT` to find a matching file. Default is `/`. Note that the restconf match prefix is `/restconf`.

Example

The following is an example of a config file for setting up an http-data service at `/var/www/data`:

```
<clixon-config xmlns="http://clixon.org/config">
  <CLICON_FEATURE>clixon-restconf:http-data</CLICON_FEATURE>
  <CLICON_HTTP_DATA_ROOT>/var/www</CLICON_HTTP_DATA_ROOT>
  <CLICON_HTTP_DATA_PATH>/data</CLICON_HTTP_DATA_PATH>
  ...
</clixon-config>
```

An example curl call could be:

```
curl -X GET -H 'Accept: text/html' http://localhost/data/
```

The call will retrieve the file at `/var/www/data/index.html`.

11.10.2 11.10.2 Features and limitation

The http server is very limited in functionality:

- No dynamic pages, ie backend scripts, only static pages are supported.
- Operations are limited to GET, HEAD, and OPTIONS
- Query parameters are not supported
- Indata is not supported
- Supported media is: html, css, js, fonts, and some images. All other content is default *octet-stream*

All applicable features of the native restconf implementation are available for the http-data as well. This includes http/1 and http/2 and TLS using openssl.

There is support for URI path internal redirect to a file called *index.html*. This can be changed by compile-time option `HTTP_DATA_INTERNAL_REDIRECT`.

11.11 11.11 RESTCONF stream notifications

Clixon has an experimental RESTCONF event stream implementations following RFC8040 Section 6 using Server-Sent Events (SSE).

Limitations are:

- *FCGI*: single request only
- Regular subscription and stop-time only

Example: set the Clixon configuration options:

```
<CLICON_STREAM_RETENTION>3600</CLICON_STREAM_RETENTION>
```

In this example, the stream `example` is accessed with `https://example.com/streams/example`.

Clixon defines an internal in-memory (not persistent) replay function controlled by the configure option above. In this example, the retention is configured to 1 hour, i.e., the stream replay function will only save timeseries one hour, but if the restconf daemon is restarted, the history will be lost.

In the Nginx configuration, add the following to extend the nginx configuration file with the following statements (for example):

```
location /streams {
    fastcgi_pass unix:/www-data/fastcgi_restconf.sock;
    include fastcgi_params;
    proxy_http_version 1.1;
    proxy_set_header Connection "";
}
```

An example of a stream access is as follows:

```
curl -H "Accept: text/event-stream" -s -X GET http://localhost/streams/EXAMPLE
data: <notification xmlns="urn:ietf:params:xml:ns:netconf:notification:1.0"><eventTime>
↪2018-11-04T14:47:11.373124</eventTime><event><event-class>fault</event-class>
↪<reportingEntity><card>Ethernet0</card></reportingEntity><severity>major</severity></
↪event></notification>
```

(continues on next page)

(continued from previous page)

```
data: <notification xmlns="urn:ietf:params:xml:ns:netconf:notification:1.0"><eventTime>
↪ 2018-11-04T14:47:16.375265</eventTime><event><event-class>fault</event-class>
↪ <reportingEntity><card>Ethernet0</card></reportingEntity><severity>major</severity></
↪ event></notification>
```

You can also specify start and stop time. Start-time enables replay of existing samples, while stop-time is used both for replay, but also for stopping a stream at some future time:

```
curl -H "Accept: text/event-stream" -s -X GET http://localhost/streams/EXAMPLE?start-
↪ time=2014-10-25T10:02:00&stop-time=2014-10-25T12:31:00
```

11.11.1 11.11.1 Fcgi stream options

The following options apply only for fcgi mode and notification streams:

CLICON_STREAM_DISCOVERY_RFC8040

Enable monitoring information for the RESTCONF protocol from RFC 8040

CLICON_STREAM_PATH

Stream path appended to CLICON_STREAM_URL to form stream subscription URL

12 SNMP

Clixon supports SNMP for retrieving / setting values and sending SNMPv2c traps via netsnmp using a MIB-YANG mapping defined in RFC6643.

12.1 12.1 Architecture

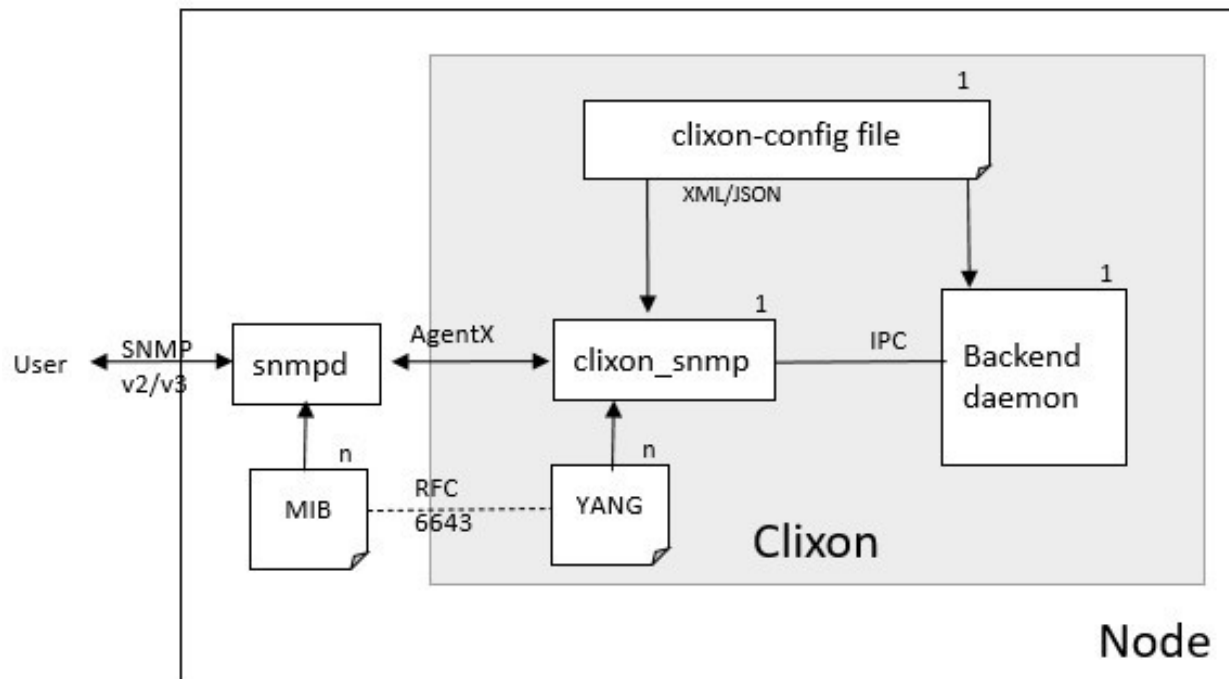

The SNMP frontend acts as an intermediate daemon between the Net-SNMP daemon (`snmpd`) and the Clixon backend. `Clixon-snm` communicates over the AgentX protocol to `snmpd` typically via a UNIX socket, and over the internal IPC protocol to the Clixon backend.

`Clixon-snm` implements RFC 6643 *Translation of Structure of Management Information Version 2 (SMIv2) MIB Modules to YANG Modules*. The RFC defines how a MIB is translated to YANG using extensions that define a mapping between YANG statements and SMI object IDs and types in the MIB.

In principle, it is also possible to construct a MIB from YANG using the same method, although this is more limited and may involve manual work.

A user can then communicate with `snmpd` using any of the SNMP v2/v3 tools, such as `snmpget`, `snmpwalk` and others.

Note:

- SNMP support is introduced in Clixon version 5.8
 - SNMPv2 traps support is introduced in Clixon version 7.2.0
-

12.2 12.2 Configuration

12.2.1 12.2.1 Net-SNMP

Note: Use Net-SNMP version 5.9 or later

To set up AgentX communication between `clixon_snmp` and `snmpd` a Unix or TCP socket is configured. This socket is also configured in Clixon (see below). An example `/etc/snmp/snmpd.conf` is as follows:

```
master      agentx
agentaddress 127.0.0.1, [:::1]
rwcommunity public localhost
agentXSocket unix:/var/run/snmp.sock
agentxperms 777 777
```

It is necessary to ensure `snmpd` does *not* to load modules implemented by Clixon. For example, if Clixon implements the IF-MIB and system MIBs, `snmpd` should not load those modules. This can be done using the “-I” flag and prepending a “-” before each module:

```
-I -ifTable -I -system_mib -I -sysORTable
```

Further, Clixon itself does not start `netsnmp` itself, you need to ensure that `netsnmp` is running when `clixon_snmp` is started. Likewise, if `snmpd` is restarted, `clixon_snmp` must also be restarted.

Note: Net-snmp must be started via `systemd` or some other external mechanism before `clixon_snmp` is started.

12.2.2 12.2.2 Clixon

To build the `snmp` support, `netsnmp` is enabled at configure time. Two configure options are added for SNMP:

- `--enable-netsnmp` Enable SNMP support.
- `--with-mib-generated-yang-dir` For tests: Directory of generated YANG specs (default: `$prefix/share/mibyang`)

Then type “make” to build the “`clixon_snmp`” executable and “make install” to install.

12.2.3 12.2.3 clixon_snmp command line options

```
$ clixon_snmp -h
usage:clixon_snmp
where options are
    -h                Help
    -V                Show version and exit
    -D <level>       Debug level
    -f <file>         Configuration file (mandatory)
    -l (e|o|s|f<file>) Log on std(e)rr, std(o)ut, (s)yslog(default), (f)ile
    -C <format>       Dump configuration options on stdout after loading and exit. Format_
↳is one of xml|json|text
    -z                Kill other clixon_snmp daemon and exit
    -o "<option>=<value>" Give configuration option overriding config file (see_
↳clixon-config.yang)
```

12.2.4 12.2.4 clixon_snmp configuration

There are two SNMP related options in the Clixon configuration:

CLICON_SNMP_AGENT_SOCK

String description of the AgentX socket that clixon_snmp listens to.

CLICON_SNMP_MIB

Names of MIBs that are used by clixon_snmp.

Example:

```
<CLICON_SNMP_AGENT_SOCK>unix:/var/run/snmp.sock</CLICON_SNMP_AGENT_SOCK>
<CLICON_SNMP_MIB>IF-MIB</CLICON_SNMP_MIB>
```

Note that the socket `/var/run/snmp.sock` is the same as configured in “snmpd.conf” above.

12.3 12.3 MIB mapping

Clixon registers MIBs with netsnmp by using YANG specifications. To achieve this, the MIB is first converted (according to RFC6643) to YANG format.

12.3.1 12.3.1 Generating YANG

MIB to YANG conversion can be done using the `smidump` tool, version 0.5 or later. Manual mapping is also possible. In Debian `smidump` is available in the package “smitools”. You may also find existing repos with converted MIBs.

To convert a MIB to YANG, invoke `smidump` with the “-f yang” flag and point it to a MIB. MIBs will usually be in the directory “/usr/share/snmp/mibs/”:

```
$ smidump -f yang /usr/share/snmp/mibs/IF-MIB.txt > IF-MIB.yang
```

Note: `smidump` 0.5 or later must be used

Once a MIB is converted to YANG, two things should be done:

- 1) The YANG is registered as an SNMP module using the CLIXON_SNMP_MIB configuration option
- 2) The YANG file must be placed so that it can be found using the regular Clixon YANG finding mechanism, as described in *Finding YANG files*

12.3.2 12.3.2 Config vs state

By default, all RFC6643 mappings are `config false`, ie, no configuration data.

To change to configuration data, a deviation statement is made as the following example illustrates:

```
deviation "/clixon-types:CLIXON-TYPES-MIB" {
  deviate replace {
    config true;
  }
}
```

For more info, see Section 11 in RFC 6643.

12.3.3 12.3.3 Types

Scalar types are mapped between SMI and YANG types using RFC6643. All types as used by IF-MIB, System and Entity MIBs are supported.

12.3.4 12.3.4 Tables

SNMP tables are supported for config and state and are mapped to YANG lists. It is possible to get and set individual values either via the SNMP API, or via any of the other CLIXON frontends.

Table indexes can be integers and non-integers. Multiple table indexes are supported.

As an implementation detail, Clixon uses the *table* abstraction in the netsnmp agent library, not *table-data* or *table-instance*.

12.3.5 12.3.5 RowStatus

Clixon supports SMIv2 RowStatus for table handling. Where RowStatus is used, the status of the row is returned and set to either *active*, *notInService* or *notReady*.

When writing the status of the row can be set to either *createAndGo*, *createAndWait*, *active* or *destroy*.

The *rowstatus* fired itself and all row values in *createAndWait* mode uses an internal cache which is held in memory by the clixon snmp agent. This internal cache is flushed to Clixon when setting a row to *active*, like a “pre-commit phase”. When *clixon_snmp* is restarted, the cache is cleared.

12.3.6 12.3.6 SNMPv2 traps

All stream notifications are converted to SNMPv2 traps and forwarded to the Net-SNMP daemon. The precondition is that an OID mapping is also defined for the notifications. If the notification has status data, it is bound to the corresponding OID and sent with the trap.

Note:

- clixon_snmp subscribes to all streams which are read from the backend.
 - The Net-SNMP daemon must be configured for sending traps. (Check trap2sink configuration in snmpd.conf config file.)
-

13 GNMI/gRPC

Clixon supports **gNMI** (gRPC Network Management Interface) via a standalone daemon `clixon_grpc`. gNMI is a gRPC-based protocol for retrieving and modifying device configuration and operational state using YANG-defined data models.

Note: Prototype gRPC/gNMI support is introduced in Clixon version 7.8

13.1 13.1 Architecture

The gRPC daemon acts as a northbound interface translating gNMI RPCs to Clixon internal IPC calls to the Clixon backend. It runs as a separate process alongside the backend and other frontends (CLI, NETCONF, RESTCONF).

```
gNMI client
  | gRPC/HTTP2 (TCP port 9339)
  v
clixon_grpc
  | Internal IPC
  v
clixon_backend
```

The transport layer uses HTTP/2 with Length-Prefixed-Message (LPM) gRPC framing. Protobuf encoding uses the `gnmi.proto` from `OpenConfig/gNMI`.

13.2 13.2 Build and Install

13.2.1 13.2.1 Dependencies

- `libnghttp2` — HTTP/2 library (already required for RESTCONF)
- `libprotobuf-c` — C protobuf runtime library
- `protoc-gen-c` — protobuf-c compiler plugin (build time only)

Enable the gRPC daemon at configure time:

```
./configure --enable-grpc
```

Then build and install:

```
make
sudo make install
```

This builds the `clixon_grpc` executable and installs proto files to `$prefix/share/clixon/proto/`.

13.3 13.3 Starting clixon_grpc

13.3.1 13.3.1 Command-line options

```
$ clixon_grpc -h
usage:clixon_grpc [options]
where options are
  -h                Help
  -D <level>       Debug level
  -f <file>        Clixon config file
  -l <s|e|o|n|f<file>>  Log on (s)yslog, std(e)rr, std(o)ut, (n)one or (f)ile
  -p <port>        gRPC listen port (default: 9339)
  -d                Daemonize
  -1                Oneshot: connect to backend and exit
```

The `-f` flag points to the same Clixon configuration file used by other daemons. The default gNMI port (9339) can be overridden with `-p`.

13.3.2 13.3.2 Configuration

No additional Clixon configuration options are needed beyond the standard configuration file. The backend must be running before `clixon_grpc` is started.

Example startup sequence:

```
clixon_backend -f /etc/clixon/example.xml -s init -d
clixon_grpc -f /etc/clixon/example.xml -d
```

13.4 13.4 Supported RPCs

13.4.1 13.4.1 Capabilities

Returns the set of YANG modules loaded by the Clixon backend together with supported encodings (JSON_IETF, JSON, ASCII).

Example:

```
grpcurl -plaintext \
  -import-path /usr/local/share/clixon/proto \
  -import-path /usr/include \
  -proto gnmi.proto \
  -d '{} localhost:9339 gnmi.gNMI/Capabilities
```

13.4.2 13.4.2 Get

Retrieves configuration and/or state data. The `type` field controls what is returned:

- ALL — configuration and state data
- CONFIG — configuration data only
- STATE — state (operational) data only

The path elements are translated to XPath for the backend query. Multiple paths in a single request are each queried independently.

Example — get a leaf:

```
grpcurl -plaintext \
  -import-path /usr/local/share/clixon/proto \
  -import-path /usr/include \
  -proto gnmi.proto \
  -d '{"path":[{"elem":{"name":"interfaces"},"name":"interface","key":{"name":"eth0"}}
  ↪ ]},"type":"ALL","encoding":"ASCII"}' \
  localhost:9339 gnmi.gNMI/Get
```

13.4.3 13.4.3 Set

Modifies configuration data. Supports three operations in a single request:

- update — merge the given value into the datastore
- replace — replace the subtree with the given value
- delete — remove the specified path

Each operation is applied in order: deletes, then replaces, then updates.

Example — set a leaf:

```
grpcurl -plaintext \
  -import-path /usr/local/share/clixon/proto \
  -import-path /usr/include \
  -proto gnmi.proto \
  -d '{"update":{"path":{"elem":{"name":"val"}}, "val":{"string_val":"hello"}}}' \
  localhost:9339 gnmi.gNMI/Set
```

13.4.4 13.4.4 Subscribe

The ONCE mode is supported. A `SubscribeRequest` with `mode=ONCE` returns current data for each subscribed path as a series of `SubscribeResponse` update messages, followed by a final `sync_response=true` message.

Example — subscribe ONCE:

```
grpcurl -plaintext \
  -import-path /usr/local/share/clixon/proto \
  -import-path /usr/include \
  -proto gnmi.proto \
  -d '{"subscribe":{"mode":"ONCE","encoding":"ASCII","subscription":[{"path":{"elem":{"
```

(continues on next page)

```
↪ "name": "val" ] ] ] ] ] ] ] ] ' \
localhost:9339 gnmi.gNMI/Subscribe
```

13.5 13.5 Encodings

The following gNMI encodings are supported:

- **JSON_IETF** — RFC 7951 JSON encoding (default for Get responses)
- **JSON** — JSON encoding
- **ASCII** — plain text (used for Subscribe responses)

PROTO and BYTES encodings are not supported.

13.6 13.6 Limitations

The following features are not yet implemented:

- **TLS** — plain TCP only; no SSL/TLS transport
- **Authentication** — no credentials or certificate validation
- **NACM** — no access control applied
- **Subscribe STREAM and POLL** — only ONCE mode is implemented
- **Subscribe encoding** — Subscribe responses always use ASCII encoding regardless of the requested encoding
- **Prefix field** — the prefix field in GetRequest and SetRequest is silently ignored; all paths must be absolute
- **Path wildcards** — * and . . . path wildcards are not supported
- **union_replace** — the Set union_replace operation is not implemented
- **use_models** — the use_models field in GetRequest is ignored

14 YANG

This chapter describes some aspects of the YANG implementation in Clixon. Regarding standard compliance, see *Standards*.

14.1 14.1 Leafrefs

Some notes on YANG leafref implementation in Clixon, especially as used in *openconfig modules*, which rely heavily on leafrefs.

Typically, a YANG leafref declaration looks something like this:

```
container c {
  leaf x {
    type leafref {
      path "../config/name"; /* referring node */
      require-instance <bool>; /* determines existing referred node */
    }
  }
  container config {
    leaf name {
      type unit32; /* "referred node" */
    }
  }
}
```

This YANG example is typical of Openconfig lists defined in the *openconfig modeling*, where a key leaf references a “config” node further down in the tree.

Other typical uses is where the path is an absolute path, such as eg path `"/network-instances/network-instance/config/name"`;

14.1.1 14.1.1 Types

Consider the YANG example above, the type of `x` is the referred node:s, in this example `uint 32`. The validation/commit process, as well as the autocli type system and completion handles accordingly.

For example, if the referred node is a more complex type such as `identityref` with options “a, b”, the completion of “x” will show the options “a,b”.

14.1.2 14.1.2 Require-instance

Assume the yang above have the following two XML trees:

```
<c>
  <x>foo</x>
</c>
```

and:

```
<c>
  <x>foo</x>
  <config>
    <name>foo</name>
  </config>
</c>
```

The validity of the trees is controlled by the `require-instance` property . According to this semantics:

- If `require-instance` is false, both trees above are valid,
- If `require-instance` is true(or not present), the upper tree is invalid and the lower is valid

In most models defined by openconfig and ietf, `require-instance` is typically false.

14.2 14.2 YANG Library

Clixon partially supports [YANG library RFC 8525](#) that provides information about YANG modules and datastores,

The following configure options are associated to the YANG library

CLICON YANG LIBRARY

Enable YANG library support as state data according to RFC8525. Default: `true`

CLICON_MODULE_SET_ID

Contains a server-specific identifier representing the current set of modules and submodules.

CLICON_XMLDB_MODSTATE

Tag datastores with RFC 8525 YANG Module Library info. See *datastore* for details on how to tag datastores with Module-set info.

The module-set of RFC8525 can be retrieved using NETCONF `get` or RESTCONF `GET` as operational data. The fields that are supported are the following:

- Content-id of the whole module-set
- Name of each module
- Namespace
- Revision
- Feature
- Submodules

The following fields are not supported

- `import-only-module`
- `deviation`

- schema
- datastore

14.2.1 14.2.1 Example

An example of a NETCONF get reply with module-state data of the main example is the following:

```
<rpc-reply xmlns="urn:ietf:params:xml:ns:netconf:base:1.0" message-id="42">
  <data>
    <yang-library xmlns="urn:ietf:params:xml:ns:yang:ietf-yang-library">
      <module-set>
        <name>default</name>
        <module>
          <name>clicon-autocli</name>
          <revision>2022-02-11</revision>
          <namespace>http://clicon.org/autocli</namespace>
        </module>
        <module>
          <name>clicon-example</name>
          <revision>2020-12-01</revision>
          <namespace>urn:example:clicon</namespace>
        </module>
        ...
      </module-set>
    </yang-library>
  </data>
</rpc-reply>
```

14.3 14.3 Extensions

Clixon implements YANG extensions. There are several uses, but one is to “annotate” a YANG specification with application-specific data that can be used in plugin code for some reason.

An extension with an argument is introduced in YANG as follows:

```
module example-lib {
  namespace "urn:example:lib";
  extension mymode {
    argument annotation;
  }
}
```

Such an extension can then be used in YANG declarations in two ways, either *inline* or *augmented*.

An inlined extension is useful in a YANG module that the designer has control over and can add extension reference directly in the YANG specification.

Assume for example that an interface declaration is extended with the extension declared above, as follows:

```
module my-interface {
  import example-lib{
    prefix exl;
  }
}
```

(continues on next page)

(continued from previous page)

```
container "interfaces" {
  list "interface" {
    exl:mymode "my-interface";
    ...
  }
}
```

If you instead use an external YANG, where you cannot edit the YANG itself, you can use augmentation instead, as follows:

```
module my-augments {
  import example-lib{
    prefix exl;
  }
  import ietf-interfaces{
    prefix if;
  }
  augment "/if:interfaces/if:interface"{
    exl:mymode "my-interface";
  }
  ...
}
```

When this is done, it is possible to access the extension value in plugin code and use that value to perform application-specific actions. For example, assume an XML interface object `x` retrieve the annotation argument:

```
char    *value = NULL;
int      exist = 0;
yang_stmt *y = xml_spec(x);

if (yang_extension_value(y, "mymode", "urn:example:lib", &exist, &value) < 0)
  err;
if (exist){
  // use extension value
  if (strcmp(value, "my-interface") == 0)
    ...
}
```

A more advanced usage is possible via an extension callback (`ca_callback`) which is defined for backend, cli, netconf and restconf plugins. This allows for advanced YANG transformations. Please consult the main example to see how this could be done.

14.4 14.4 Unique

The YANG unique statement is described in Section 7.8.3 of [RFC 7950](#). However, the RFC is somewhat vague in the descriptions of its arguments.

Clixon therefore supports two simultaneous distinct cases: multiple direct children and single descendants

14.4.1 14.4.1 Multiple direct children

This is exemplified in the RFC, such as:

```
list server {
  key "name";
  unique "ip port";
  leaf ip...
  leaf port...
```

where `ip` and `port` are direct children of `server` and the uniqueness applies to their combination in all list instances.

14.4.2 14.4.2 Single descendants

The RFC says:

schema node identifiers, which MUST be given in the descendant form

This does not exclude more elaborate schema nodes than direct children but are not explicitly allowed.

Therefore, Clixon also supports a single advanced schema node id. Such a schema node id may define a set of leafs. The uniqueness is then validated against all instances, such as for example:

```
list server {
  key "name";
  unique c/inner/value;
  container c {
    list inner {
      leaf value...
```

However, only a *single* such argument is allowed. The reason is that such a schema node may potentially refer to a set of instances (not just one) and the semantics of a combination of multiple such ids is unclear.

14.5 14.5 If-feature and anydata

The YANG if-feature statement is described in Section 7.20.2 of [RFC 7950](#). The RFC states that:

Definitions tagged with “if-feature” are ignored when the server does not support that feature.

This is implemented by doing the following to disabled YANG nodes:

- (1) Configuration data nodes are replaced locally to a single ANYDATA data. This means that XML derived from disabled features are accepted but no validation is possible.
- (2) Other YANG nodes, such as RPCs or state data are removed.

Example, assume the following YANG:

```

container c{
  if-feature A;
  leaf b {
    type string;
  }
}
rpc r {
  input {
    leaf x {
      if-feature A;
      type string;
    }
  }
}

```

If feature A is NOT enabled, the YANG is transformed to:

```

anydata c{
}
rpc r {
  input {
  }
}

```

The following config option is related:

CLICON YANG UNKNOWN ANYDATA

Treat unknown XML/JSON nodes as anydata when loading from startup db.

14.6 14.6 Schema mounts

Clixon implements Yang schema mounts as defined in: [RFC 8528: YANG Schema Mount](#) with the following restrictions:

1. A YANG mount-point can only be defined in a *presence container*.
2. Only *inline* mount-points are supported
3. *config false* mount-points are not supported

14.6.1 14.6.1 Configuration

The following configure options are associated to mount-points:

CLICON YANG SCHEMA MOUNT

Enable YANG library support as state data according to RFC8525. Should be set to: `true`

CLICON YANG DOMAIN DIR

Virtual directory for YANG isolation domains.

CLICON YANG SCHEMA MOUNT SHARE

For optimization purposes, share same YANGs of same mount-points

14.6.2 14.6.2 YANG

Mount-points are enabled by importing *ietf-yang-schema-mount* and then apply the *mount-point* extension at a presence container. Example:

```
module mymod {
  namespace "urn:example:my";
  ...
  import ietf-yang-schema-mount {
    prefix yangmnt;
  }
  list mylist {
    key name;
    leaf name {
      type string;
    }
    container myroot {
      presence "Otherwise root is not visible";
      yangmnt:mount-point "mylabel" {
        description "Root for other yang models";
      }
    }
  }
}
```

Once declared in the YANG schema, mount-points will appear dynamically in the data as they are added. For example, if a NETCONF `<edit-config>` adds the *myroot* container above, it will be recognized as a mount-point and populated with another set of YANG modules than the top-level.

Populating a mount-point with YANG schemas is made by an application-dependent callback as described in Section *Mount callback*.

14.6.3 14.6.3 State

The mount-points appear in the state-data and can be retrieved using NETCONF `get`. The data appears in two places.

First, on the top-level *schema-mounts*:

```
<schema-mounts xmlns="urn:ietf:params:xml:ns:yang:ietf-yang-schema-mount">
  <mount-point>
    <module>mymod</module>
    <label>mylabel</label>
    <config>true</config>
    <inline/>
  </mount-point>
</schema-mounts>
```

Second, at the mount-point level for all dynamically added mount-points:

```
<mylist xmlns="urn:example:my">
  <name>x</name>
  <myroot>
    <yang-library xmlns="urn:ietf:params:xml:ns:yang:ietf-yang-library">
      <module-set>
```

(continues on next page)

(continued from previous page)

```

    <name>mylabel</name>
    <module>
      <name>clixon-mount1</name>
      <namespace>urn:example:mount1</namespace>
      <revision>2023-05-01</revision>
    </module>
  </module-set>
</yang-library>
</myroot>
</mylist>

```

In this example, there is one dynamically created mount-point in the list *x* where the single YANG module *clixon-mount1* is mounted.

Note that the module-set name (*mylabel*) may define an isolated YANG *domain* as described in *YANG domains*.

14.6.4 14.6.4 Mount callback

Mount-points need to be populated with YANG schemas. This is done by defining the *ca_yang_mount* callback. The following example illustrates how this is done in a C plugin:

```

static clixon_plugin_api api = {
    ...
    .ca_yang_mount=example_mount,

```

As input the callback takes the XML mount-point, and as output a yang-lib module-set tree. It also provides how to validate the YANG schemas and whether it is read-only or read-write:

```

int
main_yang_mount(clixon_handle h,
                cxobj         *xt,
                int           *config,
                validate_level *vl,
                cxobj         **yanglib)

```

For example, the callback could return something like:

```

<yang-library xmlns="urn:ietf:params:xml:ns:yang:ietf-yang-library">
  <module-set>
    <name>mount</name>
    <module>
      <name>clixon-mount1</name>
      <namespace>urn:example:mount1</namespace>
      <revision>2023-05-01</revision>
    </module>
  </module-set>
</yang-library>

```

Clixon calls this callback when needed, such as when a new mount-point is created.

14.6.5 14.6.5 CLI

It is possible to extend the Autocli with mount-points. However, it is application-dependent. For the interested user, the [Clixon controller](#) has an adapted autocli for mount-points.

14.6.6 14.6.6 YANG domains

Using CLICON_YANG_DOMAIN_DIR it is possible to specify a directory as alternative to CLICON_YANG_MAIN_DIR for maintaining separate YANG file domains.

This allows for having YANG files with the same name and revision, but with different content.

Within a YANG domain, uniqueness of revisions is assumed, you may not have two different YANGs having the same revision in the same domain.

But in separate domains, there is no such restriction.

Virtual domain directory

First, you need to set a virtual directory with CLICON_YANG_DOMAIN_DIR, such as `/usr/local/share/domains`.

Thereafter, you specify the domain using the mount-point identifier, such as:

```
yangmnt:mount-point "mylabel";
```

The domain directory is formed by concatenating the dir with the domain:

```
/usr/local/share/domains/mylabel/
```

YANG files placed in this directory are loaded by the mounts and are isolated from other domains.

You must also ensure that the `<yang-library>` callback `ca_yang_mount` returns the domain in the module-set name as follows:

```
<yang-library xmlns="urn:ietf:params:xml:ns:yang:ietf-yang-library">
  <module-set>
    <name>mylabel</name> <--
    <module>...
```

15 EVENT NOTIFICATIONS

15.1 15.1 Overview

Clixon implements RFC 5277 NETCONF Event Notifications.

There are no pre-existing notification streams in Clixon, an application needs to define them in YANG and write some code.

The main example illustrates an EXAMPLE stream notification that triggers every 5s.

15.1.1 15.1.1 Configure options

CLICON_STREAM_DISCOVERY_RFC5277

Enable event stream discovery as described in RFC 5277. This is the main option and should be `true`.

CLICON_STREAM_DISCOVERY_RFC8040

Enable monitoring information, including streams, for RESTCONF

CLICON_STREAM_PATH

Stream path appended to URI to form, default is *stream*

CLICON_STREAM_RETENTION

Retention for stream replay buffers in seconds

15.1.2 15.1.2 Restrictions

Limited replay support

15.2 15.2 Components

This section describes which components are involved to add a new event notification stream in Clixon.

To create a new event notification, you need to define the following:

1. *YANG*: Define a schema event spec
2. *Backend*: and send server-side event messages
3. *CLI*: Subscribe to the event-stream, read and display events

15.2.1 15.2.1 YANG

The first step is to add an event notification in YANG. The notification statement is a part of the YANG specification. The main example defines an event notification following event which is also used in RFC8040 and RFC5277:

```
notification event {
  description "Example notification event.";
  leaf event-class {
    type string;
    description "Event class identifier.";
  }
  container reportingEntity {
    description "Event specific information.";
    leaf card {
      type string;
    }
  }
  leaf severity {
    type string;
  }
}
```

You can add any info to an event notification, the fields above are just examples.

15.2.2 15.2.2 Backend

The server-side first declares an event-stream, for example event `my-event`:

```
stream_add(h, "my-event", "Example notification event, 0, NULL)
```

Then, code needs to be added to generate event. This is highly application dependent.

Typically, events are either timer-based or event-based.

The main example uses a timer-based event, that is, a periodic timer is set that generates a periodic event.

One can also create an event-based event that triggers on things like commits or logs. Typically this code is added in application user code.

You create a NETCONF notification event in XML, for example:

```
<my-event xmlns="urn:myuri...">
  <data-for-this-event>....
</my-event>
```

And then, assuming `msg` is a string variable with the notification, you send it with:

```
stream_notify(h, "my-event", msg)
```

15.2.3 15.2.3 CLI

You need to register a new socket “s”:

```
int s;
clixon_rpc_create_subscription(h, "my-event", NULL, &s)
```

Save the asynchronous socket “s” and read from it separately.

There are some examples on how to do this in the clixon main example and the controller, eg here: https://github.com/clixon/clixon-controller/blob/9a3ef161106207f6a49f3fbc14e50841f20f50e3/src/controller_cli_callbacks.c#L431 But it depends on how you want the CLI to behave.

15.2.4 15.2.4 Netconf

To start a notification stream via netconf:

```
<rpc><create-subscription xmlns="urn:ietf:params:xml:ns:netmod:notification"><stream>
↳EXAMPLE</stream></create-subscription></rpc>]]>]]>
<rpc-reply><ok/></rpc-reply>]]>]]>
<notification xmlns="urn:ietf:params:xml:ns:netconf:notification:1.0"><eventTime>2019-01-
↳02T10:20:05.929272</eventTime><event><event-class>fault</event-class><reportingEntity>
↳<card>Ethernet0</card></reportingEntity><severity>major</severity></event></
↳notification>]]>]]>
```

15.2.5 15.2.5 Restconf

An example using curl:

```
curl -X GET -H "Accept: text/event-stream" -H "Cache-Control: no-cache" -H "Connection:
↳keep-alive" https://thehost/streams/
```

15.3 15.3 Main example

The main example has an integrated CLI event notification. To try out:

```
clixon_cli -f /usr/local/etc/clixon/example.xml
cli> notify
cli> event-class fault;
reportingEntity {
  card Ethernet0;
}
severity major;

cli> no notify
cli>
```

16 USECASES

This section contains usecases which illustrate the flow of data from a user via Clixon frontends, backend to the underlying system and back.

16.1 16.1 CLI read



The first usecase illustrates how a retrieval of a configured value from the system is made.

1. The user makes a *show config* call using the hello world example(see *Quickstart section*). In the following examples uses *text* as modifier, and filters on *hello* top-level symbol:

```
cli> show configuration text hello
hello world;
```

2. The CLI string *show configuration text hello* is translated to internal NETCONF and sent to the backend:

```
<?xml version="1.0" encoding="UTF-8"?>
<hello xmlns="urn:ietf:params:xml:ns:netconf:base:1.0">
  <capabilities><capability>urn:ietf:params:netconf:base:1.1</capability></capabilities>
</hello>]]>]]>
<rpc username="myuser" xmlns:nc="urn:ietf:params:xml:ns:netconf:base:1.0">
  <get-config>
    <source><candidate/></source>
    <nc:filter nc:type="xpath" nc:select="hello" xmlns="urn:example:hello"/>
  </get-config>
</rpc>
```

3. The backend receives the internal Netconf message, reads the *running* datastore and filters the output according to the XPath expression.

4. The backend returns the filtered output to the client:

```
<rpc-reply xmlns="urn:ietf:params:xml:ns:netconf:base:1.0">
  <data>
    <hello xmlns="urn:example:hello">
      <world/>
    </hello>
  </data>
</rpc-reply>
```

5. The CLI client translates the netconf to “text” output: *hello world*;

The user can also retrieve state data. Instead of reading from the running datastore, the backend reads state data either from a plugin, or from itself (if backend internal).

16.2 16.2 CLI write

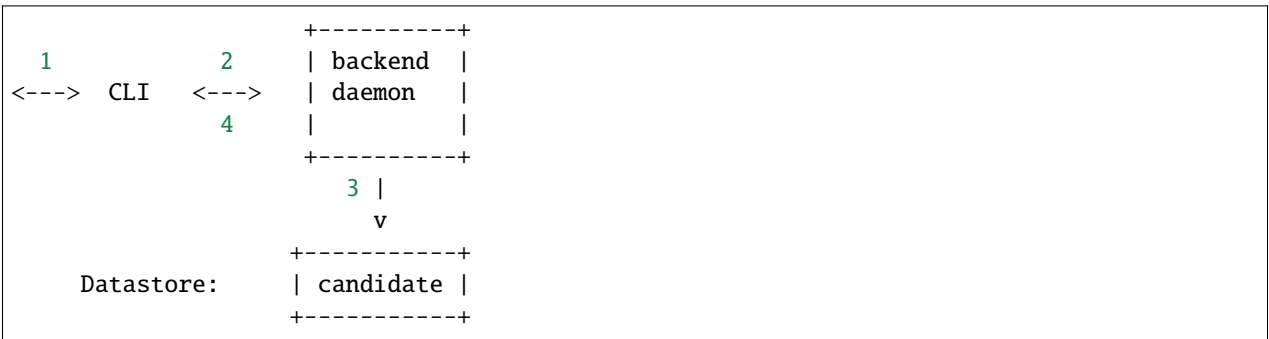

The figure illustrates the way messages flow through the system. The numbers illustrate the enumeration below.

When setting a config value, the candidate datastore is modified and the committed to running which triggers a plugin commit transaction:

1. CLI example command:

```
cli> set hello world
cli>
```

2. Internal netconf containing a “replace” operation:

```
<?xml version="1.0" encoding="UTF-8"?>
<hello xmlns="urn:ietf:params:xml:ns:netconf:base:1.0">
  <capabilities><capability>urn:ietf:params:netconf:base:1.1</capability></capabilities>
</hello>]]>]]>
<rpc xmlns="urn:ietf:params:xml:ns:netconf:base:1.0" xmlns:nc=
  ↪ "urn:ietf:params:xml:ns:netconf:base:1.0" username="clixon">
  <edit-config>
    <target><candidate/></target>
    <default-operation>none</default-operation>
    <config>
      <hello xmlns="urn:example:hello">
        <world nc:operation="replace"/>
      </hello>
    </config>
```

(continues on next page)

```
<rpc-reply xmlns="urn:ietf:params:xml:ns:netconf:base:1.0">
  <ok/>
</rpc-reply>
```

16.4 RESTCONF RPC

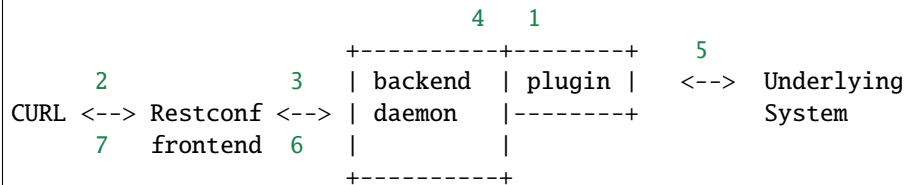

A plugin can register an application-dependent RPC, and a client can then access it.

1. A plugin registers *example-rpc*:

```
rpc_callback_register(h, example_rpc, NULL, "urn:example:clixon", "example");
```

2. A user makes an RPC call, in this case RESTCONF:

```
curl -is -X POST -H "Content-Type: application/yang-data+json" -d '{"clixon-example:input
  ↪":{"x":0}}' http://localhost/restconf/operations/clixon-example:example
```

3. The restconf client receives the HTTP POST message (via a reverse proxy such as nginx) and translates the JSON to internal NETCONF:

```
<rpc username="none">
  <example xmlns="urn:example:clixon">
    <x>0</x>
  </example>
</rpc>
```

4. The backend receives the Netconf message and calls the registered callback *example_rpc()* in the plugin.
5. The plugin processes the rpc, for example by accessing state in the underlying system
6. The plugin returns a reply which is returned to the restconf client (for example):

```
<rpc-reply xmlns="urn:ietf:params:xml:ns:netconf:base:1.0">
  <x xmlns="urn:example:clixon">0</x>
  <y xmlns="urn:example:clixon">42</y>
</rpc-reply>
```

7. The restconf client translates the Netconf message to JSON and returns to the client (via a reverse proxy):

```
{
  "clixon-example:output":{
    "x":"0",
    "y":"42"
  }
}
```

17 XML

This section describes XML trees, their creation, modification and how to search in them.

Note though, that the internal representation is abstract which may be formatted as XML and JSON for example.

17.1 XML trees

XML objects are typed as follows [XML 1.0](#):

- Element: non-terminal node with child nodes
- Attribute: name value pair
- Body: text between tags

Elements and attributes have names. An element has a set of children while body and attribute have values.

For example, the following XML tree:

```
<y xmlns="urn:example:a">
  <x>
    <k>a</k>
  </x>
</y>
```

can have an internal tree representation as follows (e represents XML element, b body and a attribute:

```
y:e -----> xmlns:a (value:"urn:example:a")
  \
   +-----> x:e -----> k:e -----> :b (value:"a")
```

17.1.1 Yang binding

Typically, XML elements are associated with a YANG data node specification(`yang_stmt`). A YANG data node is either a container, leaf, leaf-list, list, or anydata.

A YANG bound XML node have some constraints with respect to children as follows:

- All elements may have attributes
- A leaf or leaf-list has at most one body child.
- A leaf or leaf-list have no elements children
- A container or list have no body children

- A container or list may have one or many element children
- An anydata node may have both elements and one body child(>)

The XML example given earlier could have the following YANG specification:

```

module mod_a{
  prefix a;
  namespace "urn:example:a";
  container y {
    list x{
      key k;
      leaf k{
        type string;
      }
    }
  }
}

```

Annotating the tree representation with YANG specification, could yield the following YANG bound tree:

```

container y
y:e -----> xmlns:a (value:"urn:example:a")
  \
   list x      leaf k
  +-----> x:e -----> k:e -----> :b (value:"a")

```

17.1.2 17.1.2 Sorted tree

Once an XML tree is bound to YANG, it can be sorted.

The tree is sorted using a “multi-layered” approach:

1. XML type: attributes come before elements and bodies.
2. Yang nodename: XML nodes with same nodename are adjacent and follow the order they are given in the Yang specification. If XML nodes belong to different modules, they follow the order they were loaded into the system.
3. Sorting lists and leaf-lists. There are two variants:
 - a) Ordered-by-system: This is the default. Elements are sorted according to key value. Key value comparison is typed: if the key type is string, strcmp is used, if the key value is an integer, integer <>= is used, etc.
 - b) Ordered-by-user: the list items follow the ordered they were entered, regardless of list keys. Ordered-by-user is not recommended in clixon since the optimized searching algorithms uses sorted lists.

Extending the example above slightly with a new list x2 as follows:

```

list x2{
  key k2;
  leaf k2{
    type int32;
  }
}

```

could give the following sorted XML tree:

```

<y xmlns="urn:example:a">
  <x>
    <k>a</k>
  </x>
  <x>
    <k>b</k>
  </x>
  <x2>
    <k2>9</k2>
  </x2>
  <x2>
    <k2>100</k2>
  </x2>
</y>

```

Note that among `y`'s children, the attribute is the first (layer 1), then follows the group of `x` elements and the group of `x2` elements as they are given in the YANG specification (layer 2). Finally, the lists are internally sorted according to key values.

Note: Sorting is necessary to achieve fast searching as described in Section *Searching in XML*.

17.2 17.2 Creating XML

The creation of an XML tree goes through three steps:

1. Syntactic creation. This is done either via parsing or via manual API calls.
2. Bind to YANG. Assure that the XML tree complies to a YANG specification.
3. Semantic validation. Ensuring that the XML tree complies to the backend validation rules.

Steps 2 and 3 are optional.

17.2.1 17.2.1 Creating XML from a string

A simple way to create an `cxobj` is to parse it from a string:

```

cxobj *xt = NULL;
if ((ret = clixon_xml_parse_string("<y xmlns='urn:example:a'><x><k1>a</k2></x></y>",
                                YB_MODULE, yspec, &xt, NULL)) < 0)
    err;
if (ret == 0)
    err; /* yang error */

```

where

- `YB_MODULE` is the default Yang binding mode, see *Binding YANG to XML*.
- `xt` is a top-level `cxobj` containing the XML tree.
- `yspec` is the top-level yang spec obtained by e.g., `clixon_dbspec_yang(h)`

If printed with for example: `xml_print(stdout, xt)` the tree looks as follows:

```
<top>
  <y xmlns="urn:example:a">
    <x>
      <k1>a</k1>
    </x>
  </y>
</top>
```

Note that a top-level node (`top`) is always created to encapsulate all trees parsed and that the default namespace in this example is “`urn:example:a`”.

The XML parse API has several other functions, including:

- `clixon_xml_parse_file()` Parse a file containing XML
- `clixon_xml_parse_va()` Parse a string using variable argument strings

17.2.2 17.2.2 Creating JSON from a string

You can create an XML tree from JSON as well:

```
cxobj *xt = NUL;L
cxobj *xerr = NULL;

if ((ret = clixon_json_parse_string("{\"mod_a:y\":{\"x\":{\"k1\":\"a\"}}}",
    YB_MODULE, yspec, &xt, NULL)) < 0)
    err;
```

yielding the same `xt` tree as in *Creating XML from a string*.

In JSON, namespace prefixes use YANG module names, making the JSON format dependent on a correct YANG binding.

The JSON parse API also includes:

- `clixon_json_parse_file()` Parse a file containing JSON

17.2.3 17.2.3 Creating XML programmatically

You may also manually create a tree by `xml_new()`, `xml_new_body()`, `xml_addsub()`, `xml_merge()` and other functions. Instead of parsing a string, a tree is built manually. This may be more efficient but more work to program.

The following example creates the same XML tree as in the above examples using API calls:

```
cxobj *xt, *xy, *x, *xa;
if ((xt = xml_new("top", NULL, CX_ELMNT)) == NULL)
    goto done;
if ((xy = xml_new("y", xt, CX_ELMNT)) == NULL)
    goto done;
if ((xa = xml_new("xmlns", y, CX_ATTR)) == NULL)
    goto done;
if (xml_value_set(xa, "urn:example:a") < 0)
    goto done;
if ((x = xml_new("xy", xt, CX_ELMNT)) == NULL)
    goto done;
```

(continues on next page)

(continued from previous page)

```
if (xml_new_body("k1", x, "a") == NULL)
    goto done;
```

Note: If you create the XML tree manually, you may have to explicitly call a yang bind function.

17.2.4 Binding YANG to XML

A further step is to ensure that the XML tree complies to a YANG specification. This is an optional step since you can handle XML without YANG, but often necessary in Clixon, since some functions require YANG bindings to be performed correctly. This includes sort, validate, merge and insert functions, for example.

Yang binding may be done already in the XML parsing phase, and is mandatory for JSON parsing. If XML is manually created, you need to explicitly call the Yang binding functions.

For the XML in the example above, the YANG module could look something like:

```
module mod_a{
  prefix a;
  namespace "urn:example:a";
  container y {
    list x{
      key k1;
      leaf k1{
        type string;
      }
    }
  }
}
```

Binding is made with the `xml_bind_yang()` API. The bind API can be done in some different ways as follows:

- `YB_MODULE` Search for matching yang binding among top-level symbols of Yang modules. This is default.
- `YB_PARENT` Assume yang binding of existing parent and match its children by name
- `YB_NONE` Do not bind

In the example above, the binding is `YB_MODULE` since the top-level symbol `x` is a top-level symbol of a module.

But assume instead that the string `<k1 xmlns="urn:example:a">a</k1>` is parsed or created manually. You can determine which module it belongs to from the namespace, but there may be many `k1` symbols in that module, you do not know if the “leaf” one in the Yang spec above is the correct one.

The following is an example of how to bind yang to an XML tree `xt`:

```
cxobj *xt;
cxobj *xerr = NULL;
/* create xt as example above */
if ((ret = xml_bind_yang(h, xt, YB_MODULE, yspec, NULL)) < 0)
    goto done; /* fatal error */
if (ret == 0)
    goto noyang; /* yang binding error */
```

The return values from the bind API are same as parsing, as follows:

- 1 OK yang assignment made
- 0 Partial or no yang assignment made (at least one failed) and xerr set
- -1 Error

As an example of *YB_PARENT* Yang binding, the *k1* subtree is inserted under an existing XML tree which has already been bound to YANG. Such as an XML tree with the *x* symbol.

17.2.5 17.2.5 Config data

To create a copy of configuration data, a user retrieve a copy from the datastore to get a *cxobj* handle. This tree is fully bound, sorted and defaults set. Read-only operations may then be done on the in-memory tree.

The following example code gets a copy of the whole *running* datastore to *cxobj* *xt*:

```
cxobj *xt = NULL;
if (xmldb_get(h, "running", NULL, NULL, &xt) < 0)
    err;
```

Note: In the case of config data, in-memory trees are read-only *caches* of the datastore and can normally not be written back to the datastore. Changes to the config datastore should be made via the backend netconf API, eg using *edit-config*.

17.3 17.3 Modifying XML

Once an XML tree has been created and bound to YANG, it can be modified in several ways.

17.3.1 17.3.1 Merging

If you have two trees, you can merge them with *xml_merge* as follows:

```
if ((ret = xml_merge(xt, x2, yspec, &reason)) < 0)
    err;
if (ret == 0)
    err; /* yang failure */
```

where both *xt* and *x2* are root XML trees (directly under a module) and fully YANG bound. For example, if *x2* is:

```
<top>
  <y xmlns="urn:example:a">
    <x>
      <k1>z</k1>
    </x>
  </y>
</top>
```

the result tree *xt* after merge is:

```
<top>
  <y xmlns="urn:example:a">
    <x>
      <k1>a</k1>
    </x>
    <x>
      <k1>z</k1>
    </x>
  </y>
</top>
```

Note that the result tree is sorted and YANG bound as well.

17.3.2 17.3.2 Inserting

Inserting a subtree can be made in several ways. The most straightforward is using parsing and the YB_PARENT YANG binding:

```
cxobj *xy;
xy = xpath_first(xt, NULL, "%s", "y");
if ((ret = clixon_xml_parse_string("<x><k1>z</k2></x>", YB_PARENT, yspec, &xy, NULL)) <
↳0)
if (ret == 0)
    err; /* yang error */
```

with the same result as in tree merge.

Note that `xy` in this example points at the `y` node and is where the new tree is pasted. Neither tree need to be a root tree.

Another way to insert a subtree is to use `xml_insert`:

```
if (xml_insert(xy, xi, INS_LAST, NULL, NULL) < 0)
    err;
```

where both `xy` and `xi` are YANG bound trees. It is possible to specify where the new child is inserted (last in the example), but this only applies if `ordered-by user` is specified in YANG. Otherwise, the system will order the insertion of the subtree automatically.

17.3.3 17.3.3 Removing

A subtree can be permanently removed, or just pruned in order to insert it somewhere else. and graft subtrees.

Permanently deleting a (sub)tree `x` and remove or from its parent is done as follows:

```
xml_purge(x);
```

Removing a subtree `x` from its parent is done as follows:

```
xml_rm(x);
```

or alternatively remove child number `i` from parent `xp`:

```
xml_child_rm(xp, i);
```

In both these cases, the child `x` can be used as a stand-alone tree, or being inserted under another parent.

17.3.4 17.3.4 Copying

An XML tree `x0` can be copied as follows:

```
cxobj *x1;
x1 = xml_new("new", NULL, xml_type(x0));
if (xml_copy(x0, x1) < 0)
    err;
```

Alternatively, a tree can be duplicated as follows:

```
x1 = xml_dup(x0);
```

In these cases, the new object `x1` can be use as a separate tree for insertion.

17.4 17.4 Searching in XML

Clixon search indexes are either *implicitly* created from the YANG specification, or *explicitly* created using the API.

From YANG it is only `list` and `leaf-list` that are candidates for optimized lookup, direct `leaf` and `container` lookup is fast either way.

Binary search is used by search indexes and works by ordering list items alphabetically (or numerically), and then dividing the search interval in two equal parts depending on if the requested item is larger than, or less than, the middle of the interval.

Binary search complexity is $O(\log N)$, whereas linear search is $O(n)$. For example, a search in a vector of one million children will take up to 20 lookups, whereas linear search takes up to 1.000.000 lookups.

Therefore, if you have a large number of children and you need to make searches, it is important that you use indexes, either implicit, or explicit.

17.4.1 17.4.1 Auto-generated indexes

Auto-generated (or implicit) YANG-based search indexes are based on `list` and `leaf-lists`. For any list with keys `k1, . . . kn`, a set of indexes are created and an optimized search can be made using the keys in the order they are defined.

For example, assume the following YANG (this YANG is reused in later examples):

```
module mod_a{
  prefix a;
  namespace "urn:example:a";
  import clixon-config {
    prefix "cc";
  }
  list x{
    key "k1 k2";
    leaf k1{
      type string;
    }
    leaf k2{
      type string;
    }
    leaf-list y{
```

(continues on next page)

(continued from previous page)

```

    type string;
  }
  leaf z{
    type string;
  }
  leaf w{
    type string;
    cc:search_index;
  }
  ...

```

Assume also an example XML tree as follows:

```

<top xmlns="urn:example:a">
  <x>
    <k1>a</k1>
    <k2>a</k2>
    <y>cc</y>
    <y>dd</y>
    <z>ee</z>
    <w>ee</w>
  </x>
  <x>
    <k1>a</k1>
    <k2>b</k2>
    <y>cc</y>
    <y>dd</y>
    <z>ff</z>
    <w>ff</w>
  </x>
  <x>
    <k1>b</k1>
    ...
</top>

```

Then there will be two implicit search indexes created for all XML nodes *x* so that they can be accessed with $O(\log N)$ with e.g.:

- XPath or Instance-id: `x[k1="a"][k2="b"]`.
- Api-path: `x=a,b`.

If other search variables are used, such as: `x[z="ff"]` the time complexity will be $O(n)$ since there is no explicit index for *z*. The same applies to using key variables in another order than they appear in the YANG specification, eg: `x[k2="b"][k1="a"]`.

A search index is also generated for leaf-lists, using *x* as the base node, the following searches are optimized:

- XPath or Instance-id: `y[.="bb"]`.
- Api-path: `y=bb`.

In the following cases, implicit indexes are *not* created:

- No YANG definition of the XML children exists. There are several use-cases. For example that YANG is not used or the tree is part of YANG *ANYXML*.

- The list represents *state* data
- The list is *ordered-by user* instead of the default YANG *ordered-by system*.

17.4.2 17.4.2 Explicit indexes

In those cases where implicit YANG indexes cannot be used, indexes can be explicitly declared for fast access. Clixon uses a YANG extension to declare such indexes: *search_index* as shown in the example above for leaf *w*:

```
leaf w{
  type string;
  cc:search_index;
}
```

In this example, *w* can be used as a search index with $O(\log N)$ in the search API.

The corresponding direct API call is: `yang_list_index_add()`

17.4.3 17.4.3 Direct children

The basic C API for searching direct children of a `cxobj` is the `clixon_xml_find_index()` API.

An example call is as follows:

```
clixon_xvec *xv = NULL;
cvec      *cvk = NULL;

if ((xv = clixon_xvec_new()) == NULL)
  goto done;
/* Populate cvk with key/values eg k1=a k2:b */
if (clixon_xml_find_index(xp, yp, namespace, name, cvk, xv) < 0)
  err;
/* Loop over found children*/
for (i = 0; i < clixon_xvec_len(xv); i++) {
  x = clixon_xvec_i(xvec, i);
  ...
}
if (xv)
  clixon_xvec_free(xv);
```

where

<code>xp</code>	is an XML parent
<code>yp</code>	is the YANG specification of <code>xp</code>
<code>name</code>	is the name of the wanted children
<code>cvk</code>	is a vector of index name and value pairs
<code>xvec</code>	is a result vector of XML nodes.

For example, using the previous XML tree and if `name=x` and `cvk` contains the single pair: `k1=a`, then `xvec` will contain both `x` entries after calling the function:

```
0: <x><k1>a</k1><k2>a</k2><y>cc</y><y>dd</y><z>foo</a></x>
1: <x><k1>a</k1><k2>b</k2><y>cc</y><y>dd</y><z>bar</a></x>
```

and the search was done using $O(\log N)$.

17.4.4 Using paths in XML

If deeper searches are needed, i.e., not just to direct children, *paths* can be used to make a search request. There are three path variants, each with its own pros and cons:

- XPath is most expressive, but only supports $O(\log N)$ search for YANG *list* entries (not leaf-lists), and adds overhead in terms of memory and cycles.
- Api-path is least expressive since it can only express YANG *list* and *leaf-list* key search.
- Instance-identifier can express all optimized searches as well as non-key searches. This is the recommended option.

Assume the same YANG as in the previous example, a path to find *y* entries with a specific value could be:

- XPath or instance-id: `/a:x[a:k1="a"][a:k2="b"]/a:y[.="bb"]`
- Api-path: `/mod_a:x=a,b/y=bb`

which results in the following result:

```
0: <y>bb</y>
```

An example call using instance-id:s is as follows:

```
cxobj **vec = NULL;
size_t len = 0;
if (clixon_xml_find_instance_id(xt, yt, &vec, &len,
    "/a:x[a:k1=\"a\"][k2=\"b\"]/a:y[.="bb\""]") < 0)
    goto err;
for (i=0; i<len; i++){
    x = vec[i];
    ...
}
```

The example shows the usage of auto-generated key indexes which makes this work in $O(\log N)$, with the same exception rules as for direct children state in *Auto-generated indexes*.

An example call using api-path:s instead is as follows:

```
cxobj **vec = NULL;
size_t len = 0;
if (clixon_xml_find_api_path(xt, yt, &vec, &len,
    "/mod_a:x=a,b/y=bb") < 0)
    goto err;
for (i=0; i<len; i++){
    x = vec[i];
    ...
}
```

The corresponding API for XPath is `xpath_vec()`.

17.4.5 17.4.5 Multiple keys

Optimized $O(\log N)$ lookup works with multiple key YANG *lists* but not for explicit indexes. Further, less significant keys can be omitted which may result multiple result nodes.

For example, the following lookups can be made using $O(\log N)$ using implicit indexes:

```
x[k1="a"][k2="b"]/y[.="cc"]
x[k1="a"]/y[.="cc"]
x[k1="a"][k2="b"]
```

The following lookups are made with $O(N)$:

```
x[k2="b"][k1="a"]
x[k1="a"][z="foo"]
```

17.5 17.5 Internal representation

Clixon represents its internal data in an in-memory tree representation. In the C API, this data structure is called `cxobj` (Clixon XML object) and is used to represent config and state data. Typically, a `cxobj` is parsed from or printed to XML or JSON, but is really a generic representation of a tree.

A `cxobj` has several components, which are all accessible via the API. For example:

<code>name</code>	Name of node
<code>prefix</code>	Optional prefix denoting a localname according to XML namespaces
<code>type</code>	A node is either an element, attribute or body text
<code>value</code>	Attributes and bodies may have values.
<code>children</code>	Elements may have a set of XML children
<code>spec</code>	A pointer to a YANG specification of this XML node

The most basic way to traverse an `cxobj` tree is to linearly iterate over all children from a parent element node.

```
cxobj *x;
int ix = 0;
while ((x = xml_child_iter(xt, &ix, CX_ELMNT)) != NULL) {
    ...
}
```

where `CX_ELMNT` selects element children (no attributes or body text).

However, it is recommended to use the *Searching in XML* for more efficient searching.

17.6 17.6 Character encoding

Clixon implements encoding of character data as defined in [XML 1.0, Section 2.4](#).

The encoding can be illustrated as follows.

Assume a data-field value of type `string` including some special characters (wrt XML): `<description/>`. This string can be input using NETCONF or RESTCONF using XML and JSON as follows:

1. Restconf POST using JSON, eg: `{"value": "<description/>"}`
2. Restconf POST using XML regular x3 encoding, eg: `<value><description/></value>`
3. Restconf POST using XML and CDATA: `<value><![CDATA[<description/>]]></value>`
4. Netconf edit-config using XML regular encoding: `<value><description/></value>`
5. Netconf edit-config using XML CDATA: `<value><![CDATA[<description/>]]></value>`

The input is received by the backend where the value is stored in the backend as follows:

1. `<value><description/></value>`
2. `<value><description/></value>`
3. `<value><![CDATA[<description/>]]></value>`
4. `<value><description/></value>`
5. `<value><![CDATA[<description/>]]></value>`

Note that in most cases, the data is just propagated from input to datastore, except in the JSON to XML translation(case 1).

For output assuming the value above, there are two data formats to consider in the datastore above: 1) with regular x3 encoding and 2) using CDATA.

There are the following cases:

1. Restconf GET datastore entry 1 using JSON: `{"value": "<description/>"}`
2. Restconf GET datastore entry 2 using JSON: `{"value": "<![CDATA[<description/>]]>"}` (recently changed)
3. Restconf GET datastore entry 1 using XML: `<value><description/></value>`
4. Restconf GET datastore entry 2 using XML: `<value><![CDATA[<description/>]]></value>`
5. Netconf get-config datastore entry 1: `<value><description/></value>`
6. Netconf get-config datastore entry 2: `<value><![CDATA[<description/>]]></value>`

Internally, data is saved in cleartext which is encoded when translated to XML. CDATA encoding is an exception where it is stored internally as well.

18 PATHS

Clixon implements the following path techniques to navigate in XML trees:

- *XML Path Language* defined in [XPath 1.0](#) as part of XML and used in [NETCONF](#).
- *Instance-identifier* defined in [RFC 7950: The YANG 1.1 Data Modeling Language](#), a subset of XPath and used in [NACM](#),
- *Api-path* defined and used in [RFC 8040: RESTCONF Protocol](#)

18.1 18.1 XPath

Example of XPath in a NETCONF `get-config` RPC using the XPath capability:

```
<rpc xmlns="urn:ietf:params:xml:ns:netconf:base:1.0">
  <get-config>
    <source>
      <candidate/>
    </source>
    <filter type="xpath" select="/interfaces/interface[name='eth0']/description" />
  </get-config>
</rpc>
```

XPath is a powerful language for addressing parts of an XML document, including types and expressions. The following is a valid but complex XPath:

```
/assembly[name="robot_4"]//shape/name[contains(text(),'bolt')]/surface/roughness
```

Clixon uses XPaths extensively due to their expressive power. However, it is recommended to use instance-identifiers instead if you want optimized access.

18.1.1 18.1.1 Namespaces in XPaths

XPath uses [XML names](#), requiring an *XML namespace context* using the *xmlns* attribute to bind namespaces and prefixes. An XML namespace context can specify both:

- A default namespace for unprefix names (*/x/*), defined by for example: *xmlns="urn:example:default"*.
- An explicit namespace for prefixed names prefix (*/ex:x/*), defined by for example: *xmlns:ex="urn:example:example"*.

Further, XML prefixes are *not inherited*, each symbol must be prefixed with a prefix or default. That is, `/ex:x/y` is not the same as `/ex:x/ex:y`, unless `ex` is also default.

Example: Assume an XML namespace context:

```
<a xmlns="urn:example:default" xmlns:ex="urn:example:example">
```

with an associated XPath:

```
/x/ex:y/ex:z[ex:i='w']
```

then symbol `x` belongs to “urn:example:default” and symbols `y`, `z` and `i` belong to “urn:example:example”.

18.2 18.2 XPath API

This section gives a brief overview of the XPath C-API.

18.2.1 18.2.1 Datatypes

The datatypes of the XPath api are:

- `xpath_tree`: XPath parse-tree which follows the XPath 1.0 standard. Such a tree is created via parsing from an XPath in string representation and used internally.
- `xp_ctx`: A context based on the XPath standard, it is used to keep track of context nodes, and also to return results for the general case.

Results from an XPath lookup is either nodes, booleans, numbers or strings. The API is primarily focussed on returning nodes.

Note that the XPath API is independent of YANG.

18.2.2 18.2.2 Parse and print

You can parse an XPath string into an `xpath_tree` and then print the result as follows. Note that the parse-tree is quite large, even for small examples:

```
xpath_tree *xpt = NULL;
if (xpath_parse("/x/ex:y/ex:z[ex:i='w']", &xpt) < 0)
    err;
xpath_tree_print(stderr, xpt);
```

18.2.3 18.2.3 Functions

Single

The most basic function is `xpath_first` which is used for the most common case of returning a single XML node, given an XPath.

Assume an XML tree `x` as follows:

```
<y xmlns="urn:example:a">
  <x>
    <k1>a</k1>
  </x>
  <x>
    <k1>b</k1>
  </x>
</y>
```

Then, get the first XPath result as follows in C-code:

```
cvec *nsc = NULL;
if (xpath_first(x, nsc, "/y/x") < 0)
  err;
```

The call returns the node representing:

```
<x>
  <k1>a</k1>
</x>
```

Multiple

If you would rather get all results, and not just the first, use: `xpath_vec` instead as follows:

```
*nsc = NULL;
cxobj **vec = NULL;
size_t veclen;
if (xpath_vec(x, nsc, "/y/x", &vec, &veclen) < 0)
  err;
```

which returns a vector of the two elements in `vec`:

```
<x>
  <k1>a</k1>
</x>
<x>
  <k1>b</k1>
</x>
```

Generic

An XPath can return a more generic result rather than a vector of XML nodes. The other types are booleans, numbers and string. By using `xpath_vec_ctx`, you get an `xpath_ctx` in return, where the result can be any type.

The `xpath_vec_ctx` is the most generic API function call and is used by the others internally.

18.2.4 18.2.4 Matching XPathS

The API uses a namespace context, `nsc` which associates prefixes with namespaces. This follows the standard XML namespaces

XML defines a *qualified* name as:

```
Prefix ':' LocalPart
```

Prefix is bound to a namespace using the `xmlns` attribute, while in XPathS, Prefix is bound to a namespace using the `nsc` list.

In general, a call to an XPath API function is on the form:

```
xpath_vec_ctx(XML, NSC, XPATH, localonly)
```

The semantics of the XPath match follow three different variants:

1. *local* . `localonly` is set: Matching is made by name (LocalPart) only. All prefixes are ignored
2. *prefix* : `NSC=NULL`. Prefix match is made lexically, ignoring namespace binding.
3. *namespace*: prefix to namespace is looked up and the resulting namespace must match.

In other words, if you choose `localonly` in the API, XPath matching will compare names only, and if you omit the XPath namespace binding in `nsc`, the XPath matching will only match prefixes.

Examples

The three different variants are illustrated by examples.

Assume an XML as follows:

```
<y xmlns="urn:example:m" xmlns:n="urn:example:n">
  <x>
    <n:k1>a</n:k1>
  </x>
  <x>
    <n:k1>b</n:k1>
  </x>
</y>
```

Local match

If `localonly` is set, prefixes are ignored (`NSC` is ignored) and all following XPathS match:

```
/y/x/k1
/a:y/b:x/c:k1
```

Only names need to match.

Prefix match

If NSC=NULL, prefixes must match lexically. The following XPath matches:

```
/y/x/k1
/y/x/n:k1
```

The following does not:

```
/m:y/m:x/k1
```

The prefixes in the XPath and XML must be string-equal, regardless of which namespace they are associated with.

Namespace match

If NSC contains a namespace binding, prefixes are looked up and the namespaces must match.

Assume a namespace binding NSC as follows:

```
NULL : urn:example:m
n : urn:example:n
```

Then the following XPath matches:

```
/y/x/n:k1
```

Likewise, if NSC is:

```
x : urn:example:m
y : urn:example:n
```

then the following XPath matches:

```
/x:y/x:y:k1
```

The prefixes in the XPath are evaluated to namespaces that in turn must match.

18.2.5 XML and XPath mapping

You can map between XPath:s and XML via the two functions `xml2xpath` and `xpath2xml`.

For example, consider the XML of:

```
<y xmlns="urn:example:a">
  <x>
    <k1>a</k1>
  </x>
</y>
```

The corresponding XPath is `y/x[k1='a']`.

The two functions map between the two representations.

18.3 18.3 Instance-identifier

Instance-id:s are defined in YANG for some minor usage but appears in for example NACM and provides a useful subset of XPath. The subset is as follows (see Section 9.13 in YANG 1.1):

- Child paths using slashes: `/ex:system/ex:services`
- List entries for one or several keys: `/ex:system[ex:ip='192.0.2.1'][ex:port='80']`
- Leaf-list entries for one key: `/ex:system/ex:cipher[.='blowfish-cbc']`
- Position in lists: `/ex:stats/ex:port[3]`

Example of instance-id in NACM:

```
<path xmlns:acme="http://example.com/ns/itf">
  /acme:interfaces/acme:interface[acme:name='dummy']
</path>
```

Namespaces in instance-identifiers are the same as in XPaths.

18.4 18.4 Api-path

RESTCONF defines api-paths as a YANG-based path language. Keys are implicit which make path expressions more concise, but they are also less powerful

Example of Api-path in a restconf GET request:

```
curl -s -X GET http://localhost/restconf/data/ietf-interfaces:interfaces/interface=eth0/
↳description
```

Clixon uses Api-paths internally in some cases when accessing xml keys, but more commonly translates Api-paths to XPaths.

Api-path is in comparison to XPaths limited to pure path expressions such as, for example:

```
a/b=3,4/c
```

which corresponds to the XPath: `a[i=3][j=4]/c`. Note that you cannot express any other index variables than the YANG list keys.

18.4.1 18.4.1 Namespaces in Api-paths

In contrast to XPath, Api-path namespaces are defined implicitly by a YANG context using *module-names* as prefixes. The namespace is defined in the Yang module by the *namespace* keyword. Api-paths must have a Yang definition whereas XPaths can be completely defined in XML.

A prefix/module-name is *inherited*, such that a child inherits the prefix of a parent, and there are no defaults. For example, `/moda:x/y` is the same as `/moda:a/moda:y`.

Further, an Api-path uses a shorthand for defining list indexes. For example, `/modx:z=w` denotes the element in a list of `z:s` whose key is the value `w`. This assumes that `z` is a Yang list (or leaf-list) and the index value is known.

Example: Assume two YANG modules *moda* and *modx* with namespaces “urn:example:default” and “urn:example:example” respectively, with the following Api-path (equivalent to the XPath example above):

`/moda:x/modx:y/z=w`

where, as above, x belongs to “urn:example:default” and y , and z belong to “urn:example:example”.

19 PAGINATION

Pagination and scrolling is the technique of showing large amount of data in smaller chunks.

19.1 Overview

The pagination solution is based on the following drafts:

- <https://www.ietf.org/archive/id/draft-ietf-netconf-list-pagination-04.html>
- <https://www.ietf.org/archive/id/draft-ietf-netconf-list-pagination-nc-04.html>
- <https://www.ietf.org/archive/id/draft-ietf-netconf-list-pagination-rc-04.html>

The drafts define two YANGs:

- `ietf-list-pagination@2024-07-08.yang`
- `ietf-list-pagination-nc@2024-07-08.yang`

For example, the following requests a list of 120 items in chunks of 20:

```
get offset=0 limit=20
get offset=20 limit=20
...
get offset=100 limit=20
```

This is referred to as *stateless* pagination, since the state may change between “get” calls. For paging of a consistent snapshot view, consider *locked* pagination.

The pagination in Clixon currently implements the *offset*, *limit*, *where*, *sort-by* and *direction* attributes.

Note: Clixon does currently not implement the *cursor*, *locale*, *sublist-limit* and *remaining*.

19.2 19.2 Locked pagination

Using NETCONF, one can lock the datastore during a session to ensure that the data is unchanged, such as:

```
lock-db
get offset=0 limit=20
get offset=20 limit=20
...
get offset=100 limit=20
unlock-db
```

The use of locks guarantees a consistent view (snapshot) of config data, but risks indefinite blocking in a CLI pagination situation for example.

For state pagination data, database locks are not useful. Instead clixon extends the database lock mechanism with a specific *state-paginate-lock* lock that can be used by the state paginate callback developer. It works the same way as a database lock, but there is no config database associated with it, it is specially made for paginated state data only.

19.3 19.3 Pagination protocol

In RESTCONF a pagination request looks as follows:

```
GET /localhost/restconf/data/example-social:members/uint8-numbers?offset=20&limit=10
↪HTTP/1.1
Host: example.com
Accept: application/yang-collection+json
```

In NETCONF a similar request is:

```
<rpc>
  <get>
    <filter type="xpath" select="/es:members/es:uint8-numbers" xmlns:es="http://
↪example.com/ns/example-social"/>
    <list-pagination xmlns="urn:ietf:params:xml:ns:yang:ietf-list-pagination-nc">
      <offset>20</offset>
      <limit>10</limit>
    </list-pagination>
  </get>
</rpc>
```

In return, Clixon returns a reply with the requested number of entries (in NETCONF):

```
<rpc-reply>
  <data>
    <members xmlns="http://example.com/ns/example-social">
      <member>
        <member-id>alice</member-id>
        <privacy-settings>
          <post-visibility>public</post-visibility>
        </privacy-settings>
        <favorites>
          <uint8-numbers>20</uint8-numbers>
```

(continues on next page)

(continued from previous page)

```

        <uint8-numbers>21</uint8-numbers>
        ...
        <uint8-numbers>29</uint8-numbers>
    </favorites>
</member>
</members>
</data>
</rpc-reply>

```

19.4 19.4 CLI scrolling

CLIGen has a scrolling mechanism that can be integrated with pagination. For example, showing the list from the example above:

```

clixon_cli
cli> show state /es:members/es:member[es:member-id='bob']/es:favorites/es:uint64-
↪numbers cli
uint64-numbers 0
uint64-numbers 1
...
uint64-numbers 9
--More--

```

19.4.1 19.4.1 CLI callbacks

CLI scrolling is implemented by the *cligen_output* function similar to *printf* in syntax. By using *cligen_output* for all output, CLIGen ensures a scrolling mechanism.

Clixon includes an example CLI callback function that combines the scrolling mechanism of the CLI with NETCONF pagination called *cli_pagination* with the following arguments:

- *xpath* : XPath of a leaf-list or list
- *prefix* : Prefix used in XPath (only one can be specified)
- *namespace* : Namespace associated with prefix
- *format* : one of xml, text, json, or cli
- *limit* : Number of lines of the pagination window

In the main example, *cli_pagination* is called as follows:

```

show state <xpath:string> cli, cli_pagination("", "es", "http://example.com/ns/example-
↪social", "cli", "10");

```

An application can use the *cli_pagination* callback, or create a tailor-made CLI callback based on the example callback.

19.5 Backend pagination API

While pagination of config data is built-in, state data needs backend plugin callbacks. There is a special state pagination callback API where a callback is bound to an xpath, and is called when a pagination request is made on an xpath.

Such a callback is registered with an XPath and a callback as follows:

```
clixon_pagination_cb_register(h, mycallback, "/myxpath", myarg);
```

where the callback has the following signature:

```
int  
mycallback(void          *h,  
            char          *xpath,  
            pagination_data pd,  
            void          *arg)
```

The pd parameter has the following accessor functions:

```
uint32_t pagination_offset(pagination_data pd)  
uint32_t pagination_limit(pagination_data pd)  
int      pagination_locked(pagination_data pd)  
cxobj*   pagination_xstate(pagination_data pd)
```

Essentially, the state callback requests state data for list/leaf-list *xpath* in the interval [*offset*...*offset+limit*].

If *locked* is true, the plugin can cache the state data, return further requests from the same cache until the lock on the “running” database is released, thus forming an (implicit) transaction. For this, the `ca_lockdb` callback can be used as an end to the transaction of `state-paginate-lock`. Note that there is not explicit “start transaction”, the first locked pagination request acts as one.

See a detailed example in the main example.

20 UPGRADE

When Clixon starts, the backend reads a startup configuration (see *startup modes*) parses it, checks for upgrades, and validates the configuration. It can also add extra XML, outside of the normal startup. On errors, it can enter a failsafe mode.

Clixon has three upgrade methods:

- General-purpose datastore upgrade.
- Module-specific manual upgrade
- Automatic upgrade (experimental)

20.1 20.1 Options

CLICON_XMLDB_UPGRADE_CHECKOLD

At upgrade, yang bind and check datastore syntax against old Yang, default is *true*.

If not set, old content (before upgrade) is not checked.

20.2 20.2 General-purpose

A plugin registers a *ca_datastore_upgrade* function which gets called once on startup. This upgrade should be seen as a generic wrapper function to basic repair or upgrade of existing datastores. The module-specific upgrade callbacks are more fine-grained.

The general-purpose upgrade callback is usable if module-state is not available, or actions such as the following need to be done in the whole datastore:

- Remove or rename nodes
- Rename namespaces
- Add nodes

A recommended method, as shown in the example, is to make a pattern matching using XPath and then perform actions on the resulting nodes.

Example:

```
static clixon_plugin_api api = {  
    ...  
    .ca_datastore_upgrade=example_upgrade
```

(continues on next page)

```

};

/*! General-purpose datastore upgrade callback called once on startup
 * @param[in] h    Clixon handle
 * @param[in] db   Name of datastore, eg "running", "startup" or "tmp"
 * @param[in] xt   XML tree. Upgrade this "in place"
 * @param[in] msd  Info on datastore module-state, if any
 */
int
example_upgrade(clixon_handle h,
                char          *db,
                cxobj         *xt,
                modstate_diff_t *msd)
{
    cxobj    **xvec = NULL; /* vector of result nodes */
    size_t    xlen;
    cvec      *nsc = NULL; /* Canonical namespace */
    int        i;

    /* Skip other than startup datastore */
    if (strcmp(db, "startup") != 0)
        return 0;
    /* Skip if there is proper module-state in datastore */
    if (msd->md_status)
        return 0;
    /* Get canonical namespaces for using "normalized" prefixes */
    if (xml_nsctx_yangspec(yspec, &nsc) < 0)
        err;
    /* Get all xml nodes matching path */
    if (xpath_vec(xt, nsc, "/a:x/a:y", &xvec, &xlen) < 0)
        err;
    /* Iterate through nodes and remove them */
    for (i=0; i<xlen; i++){
        if (xml_purge(xvec[i]) < 0)
            err;
    }
}

```

The example above first checks whether it is the *startup* datastore and that it does not contain module-state. It then matches all nodes matching the XPath */a:x/a:y* using canonical prefixes, which are then deleted.

20.3 20.3 Module-specific upgrade

Module-specific upgrade is only available if module-state is enabled, see *Module library support*.

If the module-state of the startup configuration does not match the module-state of the backend daemon, a set of module-specific upgrade callbacks are made. This allows a user to program upgrade functions in the backend plugins to automatically upgrade the XML to the current version.

A user registers upgrade callbacks per YANG module. A user can register many callbacks, or choose wildcards. When an upgrade occurs, the callbacks will be called if they match the module and the modules have changed.

A module has changed if one of the following is true: - A module present in the startup is no longer present in the system (DEL) - A module in the system is not present in the startup (ADD) - A module present in both the startup and the system has a different revision date (CHANGE)

20.3.1 20.3.1 Registering a callback

A user registers upgrade callbacks in the backend `clixon_plugin_init()` function. The signature of upgrade callback is as follows:

```
upgrade_callback_register(h, cb, ns, arg);
```

where:

- *h* is the Clixon handle,
- *cb* is the name of the callback function,
- *ns* defines the namespace of a Yang module. NULL denotes all modules.
- *arg* is a user defined argument which can be passed to the callback.

One example of registering an upgrade of an interface module:

```
upgrade_callback_register(h, upgrade_interfaces, "urn:example:interfaces", NULL);
```

20.3.2 20.3.2 Upgrade callback

When Clixon loads a startup datastore with outdated modules, the matching upgrade callbacks will be called.

The signature of an upgrade callback is as follows:

```
int upgrade_interfaces(h, xt, ns, op, from, to, arg, cbret)
```

where:

- *xt* is the XML tree to be upgraded
- *ns* is the namespace of the YANG module.
- *op* is a flag indicating upgrading operation, one of: XML_FLAG_ADD, XML_FLAG_DEL, XML_FLAG_CHANGE. Note that this applies to per-module: whether a *module* has been added, deleted or changed.
- *from* is the revision date in the startup file of the module. It is zero if the operation is ADD
- *to* is the revision date of the YANG module in the system. It is zero if the operation is DEL

If no action is made by the upgrade callback, and thus the XML is not upgraded, the next step is XML/Yang validation.

An out-dated XML may still pass validation and the system will go up in normal state.

However, if the validation fails, the backend will try to enter the failsafe mode so that the user may perform manual upgrading of the configuration.

20.3.3 20.3.3 Example upgrade

The Clixon main example shows code for upgrading of an interface module. The example is inspired by the ietf-interfaces module that made a subset of the upgrades shown in the examples.

The code is split in two steps. The `upgrade_2014_to_2016` callback does the following transforms:

- Move `/if:interfaces-state/if:interface/if:admin-status` to `/if:interfaces/if:interface/`
- Move `/if:interfaces-state/if:interface/if:statistics` to `if:interfaces/if:interface/`
- Rename `/interfaces/interface/description` to `/interfaces/interface/descr`

The `upgrade_2016_to_2018` callback does the following transforms:

- Delete `/if:interfaces-state`
- Wrap `/interfaces/interface/descr` to `/interfaces/interface/docs/descr`
- Change type `/interfaces/interface/statistics/in-octets` to `decimal64` and divide all values with 1000

20.4 20.4 Extra XML

If the Yang validation succeeds and the startup configuration has been committed to the running database, a user may add “extra” XML.

There are two ways to add extra XML to running database after start. Note that this XML is “merged” into running, not “committed”.

The extra-xml feature is not available if startup mode is *none*. It will also not occur in failsafe mode.

20.4.1 20.4.1 Via file

The first way is via a file. Assume you want to add this xml:

```
<config>
  <x xmlns="urn:example:clixon">extra</x>
</config>
```

You add this via the `-c` option:

```
clixon_backend ... -c extra.xml
```

20.4.2 20.4.2 Reset callback

The second way is by programming the `plugin_reset()` in the backend plugin. The following code illustrates how to do this (see also `example_reset()` in `example_backend.c`):

```
int
example_reset(clixon_handle h,
              const char *db)
{
    cxobj *xt = NULL;
    yang_stmt *yspec;
```

(continues on next page)

(continued from previous page)

```

yspec = clicon_dbspec_yang(h);
/* Parse extra XML */
if (clicon_xml_parse_string("<x xmlns=\"urn:example:clicon\">extra</x>"
                           YB_MODULE, yspec, &xt, NULL) < 0)
    err;
xml_name_set(xt, "config");
/* Write to db */
if (xml_db_put(h, (char*)db, OP_MERGE, xt, NULL, NULL) < 0)
    err;
}
static clicon_plugin_api api = {
    ...
    .ca_reset=example_reset,
    ...
}

```

The `example_reset` function is registered in the plugin init code and is then called with an empty temp database (db). The code writes the extra XML into db (`xml_db_put`).

After exit of the callback, the system merges the temporary db into the running datastore in the same way as via file, ie not via a commit.

20.5 20.5 Failsafe mode

If the startup fails, the backend looks for a *failsafe* configuration in `<CLICON_XMLDB_DIR>/failsafe_db`. If such a config is not found, the backend terminates. In this mode, running and startup mode are unchanged.

If the failsafe is found, the running-db is copied to tmp-db and the failsafe config is loaded and committed into the running db.

If the startup mode was *startup*, the *startup* database will contain syntax errors or invalidated XML.

If the startup mode was *running*, the the *tmp* database will contain syntax errors or invalidated XML.

20.6 20.6 Repair

If the system is in failsafe mode (or fails to start), a user can repair a broken configuration and then restart the backend. This can be done out-of-band by editing the startup db and then restarting clixon.

In some circumstances, it is also possible to repair the startup configuration on-line without restarting the backend. This section shows how to repair a startup datastore on-line.

However, on-line repair *cannot* be made in the following circumstances:

- The broken configuration contains syntactic errors - the system cannot parse the XML.
- The startup mode is *running*. In this case, the broken config is in the *tmp* datastore that is not a recognized Netconf datastore, and has to be accessed out-of-band.
- Netconf must be used. Restconf cannot separately access the different datastores.

First, copy the (broken) startup config to candidate. This is necessary since you cannot make *edit-config* calls to the startup db:

```
<rpc xmlns="urn:ietf:params:xml:ns:netconf:base:1.0">
  <copy-config>
    <source><startup/></source>
    <target><candidate/></target>
  </copy-config>
</rpc>
```

You can now edit the XML in candidate. However, there are some restrictions on the edit commands. For example, you cannot access invalid XML (eg that does not have a corresponding module) via the edit-config operation. For example, assume *x* is obsolete syntax, then this is *not* accepted:

```
<rpc xmlns="urn:ietf:params:xml:ns:netconf:base:1.0">
  <edit-config>
    <target><candidate/></target>
    <config>
      <x xmlns="example" operation='delete' />
    </config>
  </edit-config>
</rpc>
```

Instead, assuming *y* is a valid syntax, the following operation is allowed since *x* is not explicitly accessed:

```
<rpc xmlns="urn:ietf:params:xml:ns:netconf:base:1.0">
  <edit-config>
    <target><candidate/></target>
    <config operation='replace'>
      <y xmlns="example" />
    </config>
  </edit-config>
</rpc>
```

Finally, the candidate is validate and committed:

```
<rpc xmlns="urn:ietf:params:xml:ns:netconf:base:1.0">
  <commit/>
</rpc>
```

The example shown in this Section is also available as a regression [repair test script](#).

20.7 20.7 Automatic upgrades

There is an EXPERIMENTAL xml changelog feature based on “draft-wang-netmod-module-revision-management-01” (Zitao Wang et al) where changes to the Yang model are documented and loaded into Clixon. The implementation is not complete.

When upgrading, the system parses the changelog and tries to upgrade the datastore automatically. This feature is experimental and has several limitations.

You enable the automatic upgrading by registering the changelog upgrade method in `clixon_plugin_init()` using wildcards:

```
upgrade_callback_register(h, xml_changelog_upgrade, NULL, 0, 0, NULL);
```

The transformation is defined by a list of changelogs. Each changelog defined how a module (defined by a namespace) is transformed from an old revision to a new. Example from `auto upgrade test script`:

```
<changelogs xmlns="http://clixon.org/xml-changelog">
  <changelog>
    <namespace>urn:example:b</namespace>
    <revfrom>2017-12-01</revfrom>
    <revision>2017-12-20</revision>
    ...
  </changelog>
</changelogs>
```

Each changelog consists of set of (ordered) steps:

```
<step>
  <name>1</name>
  <op>insert</op>
  <where>/a:system</where>
  <new><y>created</y></new>
</step>
<step>
  <name>2</name>
  <op>delete</op>
  <where>/a:system/a:x</where>
</step>
```

Each step has an (atomic) operation:

- rename - Rename an XML tag
- replace - Replace the content of an XML node
- insert - Insert a new XML node
- delete - Delete an existing node
- move - Move a node to a new place

A *step* has the following arguments:

- where - An XPath node-vector pointing at a set of target nodes. In most operations, the vector denotes the target node themselves, but for some operations (such as insert) the vector points to parent nodes.
- when - A boolean XPath determining if the step should be evaluated for that (target) node.

Extended arguments:

- tag - XPath string argument (rename)
- new - XML expression for a new or transformed node (replace, insert)
- dst - XPath node expression (move)

Step summary:

- rename(where:targets, when:bool, tag:string)
- replace(where:targets, when:bool, new:xml)
- insert(where:parents, when:bool, new:xml)
- delete(where:parents, when:bool)

- `move(where:parents, when:bool, dst:node)`

21 ERRORS AND DEBUG

21.1 21.1 Error reporting

21.1.1 21.1.1 Initialization

Clixon core applications typically have a command-line option controlling the logs as follows:

-l <option> Log on (s)yslog, std(e)rr, std(o)ut or (f)ile. Syslog is default. If foreground, then syslog and stderr is default. Filename is given after -f as follows: -lf<file>.

An example of a clixon error as it may appear in a syslog:

```
Mar 24 10:30:48 Alarik clixon_restconf[3993]: clixon_restconf openssl: 3993 Started
```

21.1.2 21.1.2 Configure options

The following options control the Clixon logging:

CLIXON_LOG_DESTINATION

Log destination, a bitmask of syslog, stderr, stdout, and file. Example: syslog stderr.

CLIXON_LOG_FILE

If log destination includes file, this is the log-file.

CLIXON_LOG_STRING_LIMIT

Length limitation of all debug and log strings. Default 0 means no limit.

Note that the configure options are overridden by the command-line argument -l.

21.1.3 21.1.3 C-code

In C-code, clixon error and logging is initialized by `clixon_log_init`:

```
clixon_log_init(h, prefix, upto, flags);
```

where:

- *prefix*: appears first in the error string
- *upto*: log priority as defined by `syslog(3)`, eg: LOG_DEBUG, LOG_INFO,..
- *flags*: a bitmask of where logs appear, values are: CLIXON_LOG_STDERR, _STDOUT, _SYSLOG, _FILE.

21.1.4 21.1.4 Error call

An error is typically called by `clixon_err()` and a return value of `-1` as follows:

```
clixon_err(category, errno, format, ...)
return -1;
```

where:

- *category* is an error “category” including for example “yang”, “xml” See *enum clixon_err* for more examples.
- *errno* if given, usually errors as given by `errno.h`
- *format* A variable arg string describing the error.

21.1.5 21.1.5 CLI Errors

There are several types of error messages in the CLI. The first class is “syntax” errors with things like:

```
cli> command
CLI syntax error: "foo": Unknown command
cli>
```

These are errors immediately detected by the CLIGen parser and are internally generated in CLIGen. Errors include command, syntax and type checking. They are shown on `stderr`, the CLI continues, without logging.

A second type of errors are “semantic” errors detected when processing CLI callbacks. These errors are more heavy-weight than syntax errors and are declared in code using standard `clixon Error call`. They are logged and can be directed to `syslog`, and are by default printed on `stderr`. The CLI continues after the error message is printed. Typical places are user callbacks, backend rpc errors, validation, etc, either system-defined or user-defined callbacks. They are on the form:

```
cli> command
Nov 15 15:42:56: acl_get_list: 334: Yang error: no ACLs defined
CLI command error
cli>
```

A third class of CLI errors are similar to the previous class but quits the CLI:

```
cli> command
Nov 15 15:42:56: acl_get_list: 334: Yang error: no ACLs defined
sh#
```

These errors are typically due to system functions failing in a fatal way.

21.1.6 21.1.6 Error categories

An application can specialize error handling for a specific category by using `clixon_err_cat_reg()` and a log callback. Example:

```
/* Clixon error category log callback
 * @param[in] handle Application-specific handle
 * @param[out] cb Read log/error string into this buffer
 */
```

(continues on next page)

(continued from previous page)

```

static int
my_log_cb(void *handle,
          cbuf *cb)
{
    cprintf(cb, "Myerror");
    return 0;
}

main(){
    ...
    /* Register error callback for category */
    clixon_err_cat_reg(OE_SSL, h, openssl_cat_log_cb);
}

```

In this example, “Myerror” will appear in the log string.

21.2 21.2 Debugging

21.2.1 21.2.1 Debug flags

Each clixon application has a `-D <level>` command-line option to enable debug flags when starting a program. Levels can be combined and use either symbolic or numerical values. Example:

```
clixon_cli -D default -D detail
```

Levels are separated into *subject-area* and *detail*

The subject-area levels are the following:

- `default` Default logs
- `msg` In/out messages and datastore reads
- `init` Initialization
- `xml` XML logs
- `xpath` XPath processing logs
- `yang` YANG processing logs
- `backend` Backend-specific processing
- `cli` CLI-frontend
- `netconf` Netconf-frontend
- `restconf` Restconf-frontend
- `snmp` SNMP-frontend
- `nacm` Netconf access control model
- `proc` Process handling
- `datastore` Datastore handling
- `event` Event handling
- `rpc` RPC handling
- `stream` Notification streams

- `parse` XML, YANG, XPath, etc parsing
- `validate` Validate config wrt YANG
- `app` Application-specific handling, ie any application using clixon can use this
- `app2` Application-specific 2
- `app3` Application-specific 3
- `all` All subject-area flags

The detail area levels are the following:

- `detail` Detail logging
- `detail2` Extra details
- `detail3` Probably more detail than you want

You can combine flags, so that, for example `-D 5` means default + detailed, but no packet debugs. Similarly, some messages require multiple flags, like XML + DETAIL would be `-D 20`.

21.2.2 21.2.2 Extending debug flags

An application plugin can extend the debug flags using the C-API.

For example, to add a new flag *example*, add the following call in *clixon_plugin_init()*:

```
if (clixon_debug_key_add("example", CLIXON_DBG_APP2) < 0)
    goto done;
```

The “example” flag can now be used using `-D` when starting the CLI or backend:

```
clixon_cli -D example
```

The extended flags can only be used as a command-line option, not in the *CLICON_DEBUG* since it is not defined in YANG.

Note: Extended debug flags cannot be used in YANG options

It is recommended to use the *_APP** bitmasks since they are reserved for application use, but the API can be used to associate a new flag to any bit pattern.

21.2.3 21.2.3 Explicit truncation

Implicit truncation of log and debug messages is made with the *CLICON_LOG_STRING_LIMIT* configure option. This applies unconditionally to all logs.

But some debug logs are defined as *explicit* truncation in C-code, which includes message, xml, json, and yang debug logs. Those logs can be very large and are therefore truncated to a pre-defined value (160) unless detailed logs are made.

This pre-defined level can be changed with *clixon_debug_explicit_trunc_set()*.

Example, assume you want to debug NETCONF messages o stderr:

```
> clixon_cli -D msg -l e
```

This limits the NETCONF logs to 160 bytes.

If you want to limit this further (to 80), you can either, make a plugin call (in C):

```
clixon_debug_explicit_trunc_set(80);
```

or you can set an implicit truncation (which applies to all other logs as well):

```
> clixon_cli -D msg -l e -o CLICON_LOG_STRING_LIMIT=80
```

If you instead want to restore full log length you can use detailed logging:

```
> clixon_cli -D msg -D detaul -l e
```

21.2.4 21.2.4 Debug log target

You can direct the debug logs using the `-l <option>` as follows:

- `s` : syslog
- `e` : stderr
- `o` : stdout
- `n` : none
- `f` : file, followed by a filename, eg `-f/tmp/foo`

Example:

```
clixon_backend -D 5 -lf/tmp/log.txt
```

21.2.5 21.2.5 Configure options

The following options control the Clixon debugging:

CLICON_DEBUG

Debug flags, a bitmask of debug values. Example: `msg app2`

21.2.6 21.2.6 Change debug

You can also change debug level in run-time in different ways. For example, using netconf to change debug level in backend:

```
echo "<rpc username=\"root\" xmlns=\"urn:iETF:params:xml:ns:netconf:base:1.0\"><debug_
↪ xmlns=\"http://clixon.org/lib\"><level>1</level></debug></rpc>]]>]]>" | clixon_netconf_
↪ -q0
```

In this example, netconf is run using EOM encoding and does not require hello:s.

Using curl to change debug in backend via the restconf daemon:

```
curl -Ssik -X POST -H "Content-Type: application/yang-data+json" http://localhost/
↪ restconf/operations/clixon-lib:debug -d '{"clixon-lib:input":{"level":1}}'
```

21.2.7 21.2.7 Debugger

Enable debugging when configuring (compile-time):

```
./configure --enable-debug
```

which includes symbol table info so that you can make breakpoints on functions(output is omitted):

```
> sudo gdb clixon_backend
(gdb) run -FD 1 -l e
Starting program: /usr/local/sbin/clixon_backend -FD 1 -l e
(gdb) b main
Breakpoint 1 at 0x5555555bcea: file backend_main.c, line 492.
(gdb) where
#0 main (argc=5, argv=0x7fffffff4e8) at backend_main.c:492
```

In the example, the backend runs in the foreground(-F), runs with debug level *l* and directs the debug messages to stderr.

21.2.8 21.2.8 Valgrind and callgrind

Examples of using valgrind for memeory checks:

```
valgrind --leak-check=full --show-leak-kinds=all clixon_netconf -qf /tmp/myconf.xml -y /
↳tmp/my.yang
```

Example of using callgrind for profiling:

```
LD_BIND_NOW=y valgrind --tool=callgrind clixon_netconf -qf /tmp/myconf.xml -y /tmp/my.
↳yang
sudo kcachegrind
```

Or massif for memory usage:

```
valgrind --tool=massif clixon_netconf -qf /tmp/myconf.xml -y /tmp/my.yang
massif-visualizer
```

21.3 21.3 Customization

Errors, logs and debug messages can be customized by plugins via the *ca_errmsg* API. There is also an error-message extension for leafrefs.

21.3.1 21.3.1 Error message extension

The `error-message` extension to `clixon-lib.yang` allows for customized error messages to types. Only leafref types are supported.

Example, assume the following extended YANG example from RFC 7950:

```
import clixon-lib {
  prefix cl;
}
...
leaf mgmt-interface {
  type leafref {
    path "../interface/name";
    require-instance true;
    cl:error-message "The interface is not found";
  }
}
```

An assignment to “`mgmt-interface`” of e.g., `eth3`, which fails validation of the existing interfaces will show the following error message:

```
The interface is not found e3
```

21.3.2 21.3.2 Errmsg API

Customized errors applies to all clixon applications. For example, logs for the backend and return output in the CLI.

The API provides a single function callback which can be used in a various ways. The example shows one simple way as described here.

First define an error message callback as part of the plugin initialization:

```
static clixon_plugin_api api = {
  ...
  .ca_errmsg=example_cli_errmsg,
};
```

The `errmsg` callback has many parameters. Some are not always applicable:

- `h`: Clixon handle
- `fn`: name of source file (only `err`)
- `line`: line of source file (only `err`)
- `type`: `log`, `err` or `debug` (actual types called `LOG_TYPE_LOG` etc)
- `category`: Error category (see Section *Error categories*) (only `err`)
- `suberr`: Error number, eg `errno` (only `err`)
- `xerr`: XML structure, either `NETCONF` (for `err`) or just generic XML (`debug`, `log`)
- `format`: Format string similar to `printf`
- `ap`: Variable argument list associated with `format`. Similar to `vprintf`
- `cbmsg`: Customized error message as output of the function. If `NULL`, use regular message.

A simple way to replace all error messages would be:

```
int
example_cli_errmsg(clixon_handle h,
                  const char *fn,
                  const int line,
                  enum clixon_log_type type,
                  int *category,
                  int *suberr,
                  cxobj *xerr,
                  const char *format,
                  va_list ap,
                  cbuf **cbmsg)
{
    if (type != LOG_TYPE_ERR)
        return 0;
    if ((*cberr = cbuf_new()) == NULL){
        fprintf(stderr, "cbuf_new: %s\n", strerror(errno));
        return -1;
    }
    cprintf(*cberr, "My error message");
    *category = 0;
    *suberr = 0;
    *retval = 0;
done:
    return *retval;
}
```

All error message are now:

```
My error message
```

Which may not be useful.

More logic needs to be added, for example a more advanced classification and translation/changing of error messages. Any field can be used to classify. The *format* string and the *ap* objects may be translated/converted which is out-of-scope of this document.

21.3.3 21.3.3 Indirection

The customized callback may also be changed dynamically. The example shows an extra indirection layer, where a new function is registered before a call, and deregistered after.

Please see the main example, where *example_cli_errmsg* just dispatches the call to a dynamic *myerrmsg*.

These are sections that do not fit into the rest of the document.

22.1 22.1 High availability

This is a brief note on a potential future feature.

Clixon is mainly a stand-alone app tightly coupled to the application/device with “shared fate”, that is, if clixon fails, so does the application.

That said, the primary state is the *backend* holding the *configuration datastore* that can be shared in several ways. This is not implemented in Clixon, but potential implementation strategies include:

- *Active/standby*: With a standard failure/liveness detection of a master backend, a standby could be started when the master fails using “-s running” (just picking up the state from the failed master). The cache write-through mechanism supports this. Would suffer from outage during standby boot. One way already possible today is using existing detection/restart mechanisms in SystemD for example.
- *Active/active*: Would need an active cache coherence algorithm. Would also need a failure/liveness detection.

In both cases the *config-db* would be a single-point-of-failure but could be mitigated by a replicated file system, for example.

Regarding clients:

- the *CLI* and *NETCONF* clients are stateless and spun up on demand.
- the *RESTCONF* daemon is stateless and can run as multiple instances (with a load-balancer)

22.2 22.2 Process handling

Clixon has a simple internal process handling currently used for *internal restconf* but can also be used for user applications. The process data structure has a unique name with pids created for “active” processes. There are three states:

STOPPED

pid=0, No process running

RUNNING

pid is set, Process started and assumed running

EXITING

pid set, Process is killed by parent but not waited for (eg not

22.3 22.3 Formats

22.3.1 22.3.1 Other formats

While only XML and JSON are currently supported as datastore formats, Clixon also supports *CLI* and *TEXT* formats for printing, and saving and loading files.

The main example contains example code showing how to load and save a config using other formats.

Example of showing a config as XML, JSON, TEXT and CLI:

```
cli> show configuration xml
<table xmlns="urn:example:clixon">
  <parameter>
    <name>a</name>
    <value>17</value>
  </parameter>
  <parameter>
    <name>b</name>
    <value>99</value>
  </parameter>
</table>
cli> show configuration json
{
  "clixon-example:table": {
    "parameter": [
      {
        "name": "a",
        "value": "17"
      },
      {
        "name": "b",
        "value": "99"
      }
    ]
  }
}
cli> show configuration text
clixon-example:table {
  parameter a {
    value 17;
  }
  parameter b {
    value 99;
  }
}
cli> show configuration cli
set table parameter a
set table parameter a value 17
set table parameter b
set table parameter b value 99
```

Save and load a file using TEXT:

```
cli> save foo.txt text
cli> load foo.txt replace text
```

Internal C API

CLI show and save commands uses an internal API for print, save and load of the formats. Such CLI functions include: *cli_show_config*, *cli_pagination*, *load_config_file*, *save_config_file*.

The following internal C API is available for output:

- XML: `clixon_xml2file()` and `clixon_xml2cbuf()` to file and memory respectively.
- JSON: `clixon_json2file()` and `clixon_json2cbuf()`
- CLI: `clixon_cli2file()`
- TEXT: `clixon_txt2file()`

The arguments of these functions are similar with some local variance. For example:

```
int
clixon_xml2file(FILE          *f,
                cxobj         *xn,
                int           level,
                int           pretty,
                clicon_output_cb *fn,
                int           skiptop,
                int           autocliext)
```

where:

- *f* is the output stream (such as *stdout*)
- *xn* is the top-level XML node
- *level* is indentation level to start with, normally 0
- *pretty* makes the output indented and use newlines
- *fn* is the output function to use. *NULL* means *fprintf*, *clicon_output* is used for scrolling in CLI
- *skiptop* only prints the children by skipping the top-level XML node *xn*
- *autocliext* Set if you want to activate autocli extensions (eg *hide* extensions)

22.4 22.4 Event handling

Clixon uses a single-threaded non-preemptive event handling.

A program registers events and timeouts.

CLICON_EVENT_SELECT

Enable select-based event-handling. Otherwise use poll-based event handling

Select-based event-handling have scaling limitations since only 1024 file descriptors are supported. However, select-based event-handling may be more robust, since poll-based event handling was introduced in Clixon 7.4.